



Military Postal Service Procedures Manual (MPM)

Originating Component:	Military Postal Service Agency (MPSA)
Effective:	December 9, 2022
Change 4 Effective:	June 26, 2024
Releasability:	Cleared for public release. This manual is available at: https://www.army.mil/mpsa .
Reissues:	Military Postal Service Procedures Manual (MPM) Dated December 9, 2022
Approved by:	BG Gregory S. Johnson, Executive Director, MPSA
Change 4 Approved by:	David L. Ernst, Deputy Director, MPSA

Authority. In accordance with (IAW) the authorities granted in Department of Defense (DoD) Directive (DoDD) 5101.11e, the Secretary of the Army was designated the DoD Executive Agent for the Military Postal Service (MPS) and Official Mail Program (OMP). The Secretary of the Army further delegated this responsibility to the Army G1. The Executive Director of the MPSA, operates under that authority, direction, and control to achieve efficient and responsive processing, transportation, and distribution of personal and official mail within the DoD. This includes the establishment and maintenance of a procedure's manual for the MPS and OMP, referred to in this manual as MPS, to integrate uniform worldwide postal processes and techniques.

Applicability. This manual applies to Office of the Secretary of Defense (OSD), the Military Departments, the Office of the Chairman of the Joint Chiefs of Staff (CJCS) and the Joint Staff, the Combatant Commands, the Office of Inspector General of the DoD, the Defense Agencies, the DoD Field Activities, and all other organizational entities within the DoD (referred to collectively in this manual as the "DoD Components").

Purpose. This manual establishes procedures, assigns responsibilities, and prescribes guidance governing the operations and use of the MPS and OMP by DoD Components pursuant to Sections 406, 3401, and 3406 of Title 39, United States Code (U.S.C.) and IAW DoDD 5101.11e, DoD Instruction (DoDI) 4525.09 and United States Postal Service (USPS) Publication 38.

SUMMARY OF CHANGES

SUMMARY OF CHANGE 4.

1. Paragraph 13.1.c. Added: The DoD shall train DoD postal personnel, appoint them in writing, and assign only qualified postal personnel to positions in the MPS. All assigned personnel must meet minimum current Federal Investigative Standards for personnel security. A person disciplined for an action reflecting unfavorably upon their integrity will not perform postal duties.
2. Paragraph 13.2. Changed to read: Requirement. Qualified postal personnel are uniformed service members who have received formal postal training at the DoD accredited postal school or a DoD civilian employee who has received informal training from qualified postal personnel within six (6) months of employment. The DoD accredited postal school is the Interservice Postal Training Activity (IPTA).
3. Paragraph 13.2.a. Changed to read: Formal Training. Attend and pass training listed in Appendix 13A as appropriate for supervisors and clerks at the IPTA, or by an associated MTT. This includes virtual or visual media instruction (provided by the IPTA, or associated MTT). Formal training is required for uniformed service members prior to initial assignment as a postal clerk or a postal supervisor.
4. Paragraph 13.2.c. Changed to read: Continuum Training. Addresses development at all levels of an organization, with relative targeted training. It also serves as refresher training for personnel who have not served in a postal position for an extended period of time.
5. Appendix 13A: Inter-Service Postal Training Activity (IPTA) Approved Program of Instruction (POI) for the Postal Operations and Postal Supervisor Courses. Added to provide the common set of basic criteria as coordinated and approved by MPSA and the Military Services which also meets the standards established by DoDI 4525.09.
6. G.1: Acronyms. Added acronyms: (1) EC-Eagle Cash. (2) ICL-Individual Country Listing. (3) ITRO-Inter-service Training Review Organization. (4) POI-Program of Instruction. (5) SAM-Space Available Mail. (6) TCMD Transportation Control and Movement Document.
7. G.2 Definitions. Added definition: Military Post Office (MPO) Capability. Refers to the size of the facility, number of receptacles (if applicable), and number of postal personnel.

Military Postal Service Procedures Manual (MPM)

Transmittal Letter.

a. Explanation. The Military Postal Service Procedures Manual (MPM) is frequently revised with updated procedures for field units. This edition replaces the prior edition dated April 19, 2024.

b. Change Process. Once the initial MPM is published in the Automated Military Postal System (AMPS) for internal DoD postal personnel use, MPSA will provide the document (PDF) on a public facing website.

(1) The MPM will be updated on an as needed basis, and when updating MPSA will use a formal process in AMPS. Operational Changes driven by USPS, Title, U.S. Code, Law, Regulation, or directive will be made as required. Users may submit update requests via AMPS, and MPSA will use a formal process to evaluate requests from the perspective of need, impact, legal authority, cost, and DoD application.

(2) Edits to the document after initial publication will be highlighted on a “Summary of Changes” page at the beginning of the updated manual, with the new date of issuance listed on the “Transmittal Letter” page. Old versions of the MPM will be archived in AMPS.

(3) Within the document, changes will be highlighted in blue font for ease of reference. When future (updated) versions to the manual occur, previous blue highlighted font will change to black, and any new edits listed on the summary of change page will be highlighted in blue within the document.

c. Availability. The MPM is available on AMPS at <http://amps.usps.gov/> and (public facing website) at <https://www.army.mil/MPSA#org-manual/>. All prior versions of the MPM are obsolete; please recycle all copies.

d. Comments and Questions. Address any comments or questions on the content of this manual to:

Plans and Policy Division
Military Postal Service Agency
2530 Crystal Drive, Ste 13101
Arlington, VA 22202-3965

TABLE OF CONTENTS

SECTION 1: MILITARY POSTAL SERVICE PRINCIPLES	9
SECTION 2: RESPONSIBILITIES	11
2.1. The Under Secretary of Defense for Acquisition and Sustainment	11
2.2. Assistant Secretary of Defense for Sustainment	11
2.3. Department of Defense Components	11
2.4. Military Service	11
2.5. The office of the Secretary of The Army	12
2.6. Combatant Commanders (through the Chairman of the Joint Chiefs of Staff)	12
2.7. Executive Director of the Military Postal Service Agency	13
2.8. Joint Military Postal Activity	13
2.9. Service Component Command	13
2.10. Military Mail Terminal	15
2.11. Commanding Officer Responsible for Postal	15
2.12. Postal Officer or Military Post Office Supervisor	16
2.13. Official Postal Manager	17
2.14. Postal Finance Officer	17
2.15. Custodian of Postal Effects/Stock Custodian	18
2.16. Postal Clerk	18
2.17. Hand-Receipt Holder	19
2.18. Tenant Commander	19
2.19. Unit Postal Officer	19
2.20. Unit Postal Clerk	20
2.21. (Unit) Postal Orderly	20
SECTION 3: ADMINISTRATIVE	22
3.1. Exception to Policy	22
3.2. International Exchange Office	22
3.3. Standard Operating Procedures	23
3.4. Military Postal Service Procedures Manual (MPM) Governance	23
APPENDIX 3A: MPS PUBLICAION SUGGESTION AND REVIEW PROCESS FLOWCHART	27
SECTION 4: ESTABLISHING AND DISESTABLISHING POSTAL SERVICE	28
4.1. General	28
4.2. Requirement	28
SECTION 5: POSTAL DEPLOYMENT PLANNING	31
5.1. General	31
5.2. Requirement	32
APPENDIX 5A: POSTAL PLANNING CHECKLIST	34
SECTION 6: MAIL COVERS	42
6.1. General	42
6.2. Requirement	42

APPENDIX 6A: MPS MAIL COVER REQUEST	44
APPENDIX 6B: POSTAL MATTER INFORMATION COLLECTION SHEET	45
SECTION 7: SEARCHES, INSPECTIONS, SEIZURES AND FRUSTRATED POSTAL	46
7.1. General	46
7.2. Requirement	47
SECTION 8: PHYSICAL SECURITY	50
8.1. General	50
8.2. Requirement	50
SECTION 9: WITHDRAW/LIMIT MILITARY POSTAL SERVICE PRIVILEGES	53
9.1. General	53
9.2. Requirement	53
SECTION 10: SUPPORT FOR COALITION FORCES AND UNITED NATIONS	55
10.1. General	55
10.2. Requirement	55
SECTION 11: ENEMY PRISONERS OF WAR/DETAINED PERSONNEL/INTERNEES	57
11.1. General	57
11.2. Requirement	57
SECTION 12: POSTAL PERSONNEL	58
12.1. General	58
12.2. Requirement	58
SECTION 13: TRAINING	61
13.1. General	61
13.2. Requirement	61
APPENDIX 13A: INTER-SERVICE POSTAL TRAINING ACTIVITY (IPTA) APPROVED PROGRAM OF INSTRUCTION (POI) FOR THE POSTAL OPERATIONS AND POSTAL SUPERVISOR COURSE	65
SECTION 14: ADDRESS MANAGEMENT	73
14.1. General	73
14.2. Requirement	73
SECTION 15: FACILITIES	74
15.1. General	74
15.2. Requirement	74
APPENDIX 15A: MILITARY POSTAL ACTIVITY DESIGN	78
APPENDIX 15B: MILITARY POSTAL OFFICE LAYOUT EXAMPLE	80
APPENDIX 15C: FACILITY AND EQUIPMENT UPGRADE PLAN	81
APPENDIX 15D: CONTINUITY OF OPERATIONS PLAN	82
APPENDIX 15E: FACILITY HOUSEKEEPING STANDARDS	83

SECTION 16: EQUIPMENT AND SUPPLIES	84
16.1. General	84
16.2. Requirement	84
SECTION 17: MOBILE ROUTING INSTRUCTIONS	86
17.1. General	86
17.2. Requirement	86
SECTION 18: MANAGEMENT OF DELIVERY RECEPTACLES	87
18.1. General	87
18.2. Requirement	87
SECTION 19: PROGRADE POSTAL PROCESSING AND DELIVERY	90
19.1. General	90
19.2. Requirement	90
APPENDIX 19A: MILITARY POST OFFICE PROCESSING/DELIVERY FLOW	93
APPENDIX 19B: PERSONNEL EXCHANGE PROGRAM MAIL RESPONSIBILITIES MEMORANDUM	94
SECTION 20: ACCOUNTABLE MAIL	95
20.1. General	95
20.2. Requirement	95
SECTION 21: DIRECTORY	97
21.1. General	97
21.2. Requirement	97
SECTION 22: CASUALTY MAIL	103
22.1. General	103
22.2. Requirement	103
SECTION 23: REGISTERED MAIL	105
23.1. General	105
23.2. Requirement	105
SECTION 24: RETAIL MANAGEMENT OPERATIONS	108
24.1. General	108
24.2. Requirement	109
SECTION 25: AUDITS	112
25.1. General	112
25.2. Requirement	112
APPENDIX 25A: HOW TO AUDIT MPS ACCOUNTS	115
Table 1: How to Audit a Fixed Credit Account	115
Table 2: How to Audit a Flexible Credit Account	116
Table 3: How to Audit a Retail Systems Software (RSS) Account	117

Table 4: How to Audit a Money Order Account	117
Table 5: How to Audit a Postage Meter Account	117
SECTION 26: SCANNING	118
26.1. General	118
26.2. Requirement	118
SECTION 27: GLOBAL TRADE COMPLIANCE	119
27.1. General	119
27.2. Requirement	119
SECTION 28: DISPATCH	121
28.1. General	121
28.2. Requirement	121
SECTION 29: TRANSPORTATION	123
29.1. General	123
29.2. Requirement	123
SECTION 30: INTRA/INTER-THEATER DELIVERY SERVICE	125
30.1. General	125
30.2. Requirement	125
SECTION 31: POSTAL NET ALERT	127
31.1. General	127
31.2. Requirement	127
SECTION 32: IRREGULARITIES	128
32.1. General	128
32.2. Requirement	128
SECTION 33: INQUIRIES	129
33.1. General	129
33.2. Requirement	129
SECTION 34: CLAIMS	130
34.1. General	130
34.2. Requirement	130
SECTION 35: POSTAL REPORTS	131
35.1. General	131
35.2. Requirement	131
SECTION 36: INSPECTIONS	132
36.1. General	132
36.2. Requirement	132
APPENDIX 36A: MILITARY POSTAL ACTIVITY INSPECTION CHECKLIST	133

SECTION 37: FREE MAIL	136
37.1. General	136
37.2. Requirement	136
SECTION 38: INFORMATION MANAGEMENT	137
38.1. General	137
38.2. Requirement	137
APPENDIX 38A: POSTAL FORMS PROCUREMENT AND RETENTION	138
SECTION 39: ABSENTEE BALLOTS AND ELECTION MATERIAL	139
39.1. General	139
39.2. Requirement	139
SECTION 40: BILLING	141
40.1. General	141
40.2. Requirement	141
SECTION 41: DoD BUSINESS/OFFICIAL MAIL	142
41.1. General	142
41.2. Requirement	142
GLOSSARY	150
G.1. Acronyms	150
G.2. Definitions	154
G.3. Forms and Supply Items	165
REFERENCES	167

SECTION 1: MILITARY POSTAL SERVICE (MPS) PRINCIPLES

1.1. The MPS operates as an extension of the United States Postal Service (USPS), consistent with public law and federal regulations. This manual contains procedures governing the use of the MPS and is applicable to all DoD Components and other government agencies (OGAs). The MPS provides efficient and responsive postal services to authorized personnel during peacetime and contingency operations.

1.2. Components must use the Automated Military Postal System (AMPS). Components identifying capability gaps will submit AMPS suggestions for modifications to MPSA. Components requiring an exception to using AMPS, must submit an Information Memorandum through their chain of command to MPSA prior to developing, acquiring, or using another technology (hardware or software) for MPS operations and records management. A sample Memorandum is located in AMPS Knowledge Management. Components will phase out alternate technologies once the AMPS capability gap is mitigated NTE 24 months. This ensures the efficient integration and optimization of uniform postal policies and processes across USPS and DoD.

1.3. The Military Services are designated with roles and responsibilities within the MPS for security, processing, transportation, and distribution of postal items.

1.4. DoD is not authorized to duplicate USPS provided services in the U.S. and its territories. There must not be an overlap of postal service between elements of the MPS and non-DoD courier or Department of State (DoS) diplomatic mail or pouch systems.

1.5. Defense agencies and activities are responsible for funding postage and fees associated with Business/Official Mail. Military Departments are also responsible for funding transportation costs to and from designated USPS airport gateways and overseas, and between intra/inter-theater locations.

1.6. DoD entities, OGAs, and non-Government organizations (NGO) authorized the use of the MPS must reimburse the Military Departments for transportation costs per U.S.C., Title 31 Section 1535 and DoD Instruction (DoDI) 4000.19.

1.7. Military Airlift (MILAIR) transportation may be used OCONUS (between inter/intra-theater locations); as well as between OCONUS locations and CONUS aerial ports of embarkation (APOE) or aerial ports of debarkation (APOD) when there are special circumstances – with prior approval from the Combatant Commander (CCDR).

1.8. The DoD provides assistance to the USPS when requested in the management and processing of civil mailings at international transit locations per the Protocol for Alarm Resolution at International Transit Sites (PARITS) & DoD Memorandum of Understanding (MOU).

1.9. Classified material must be transported and handled per DoD 5200.01 Volume 3.

1.10. The security and accountability of mail, postal property and effects is the responsibility of the Military Services, or agency. Always maintain established quality controls to prevent loss, theft, tampering, damage, willful delay, or compromise; as well as to prevent the introduction of contraband, prohibited materials and dangerous/hazardous goods.

1.11. Postal personnel shall possess a valid driver's license when duties require driving a vehicle.

1.12. All Patrons entering a Military Postal Activity (MPA) to obtain services, must show a DoD issued ID card, a CAC, or a U.S. Government Agency issued ID Card. In addition:

1.12.1. Unit Postal Clerks (UPC) must have a current Designation Letter of Appointment on file at the servicing MPA to receive unit postal support services.

1.12.2. Contractors granted MPS privileges must present a copy of their contract letter of authorization (LOA).

1.13. Days of service, as well as customer service hours shall be coordinated with the commander responsible for postal services on the installation. The operating hours of an MPA should be based on available resources, trained work force, patron usage, and ability to receipt and dispatch postal on a consistent basis.

1.14. Patrons are responsible for picking up mail daily.

1.15. Patrons will notify the servicing MPA of temporary or permanent address change and/or submit a change of address (COA) for moves in the USPS website. MPAs submit COA requests on behalf of patrons via the Automated Military Postal System (AMPS).

1.16. Organizations and personnel authorized use of the MPS will not serve as intermediaries for any person or organization. DoD incurs international air transportation costs for movement of military mail to, throughout, and from overseas destinations. The MPS will not be used to:

1.16.1. Send or receive items to advertise home businesses, to sell merchandise, conduct business, or for commercial purposes where DoD funds mail transportation costs.

1.16.2. Receipt and distribution of humanitarian aid. Military Post Offices (MPO) will not accept/deliver postal items knowing the contents are for humanitarian aid purposes.

1.16.3. Receipt of "Any Service Member" (ASM) mail, care packages, or donated items for distribution from an individual, charitable group, or organization.

1.17. Mail USPS forms and equipment using the USPS indicia.

1.18. Postal personnel shall complete AMPS Knowledge Management training requirements in accordance with roles and responsibilities assigned.

SECTION 2: RESPONSIBILITIES

Refer to DODD 5101.11E and DoDI 4525.09 for a comprehensive list of responsibilities associated with key agencies and positions listed in paragraph 2.1 through 2.7 this issuance:

2.1. Under Secretary of Defense for Acquisitions and Sustainment USD(A&S).

2.2. Assistant Secretary of Defense for Sustainment.

2.3. DoD Components. DoD components that have established, and are operating MPAs shall use the following procedures:

- a. Use AMPS modules and reporting procedures.
- b. Ensure an annual inventory is conducted of all serialized postal equipment on-hand and/or issued to a Hand-Receipt Holder (HRH). Ensure all serialized postal equipment items are accounted for properly via a PS Form 1590, PS Form 4805 or PS Form 969 via AMPS.
- c. Confirm annual training of all Official Postal Managers (OPM) is completed via AMPS.
- d. Ensure the agency's OMP is performed in accordance with DoD policy, and updates are implemented as required.
- e. Issue internal instructions for the control and use of official mail (OM) entered in the USPS or the MPS network. Instructions should include written procedures to limit increased costs, mitigate security vulnerabilities, and maintain accountability of OM sent to an alternate worksite or a telework location.

2.4. Military Services. Military Services that have established, and are operating MPAs shall use the following procedures:

- a. Designate in writing a Service Manager to provide oversight and management of the day-to-day operation of the MPS.
- b. Provide supplemental and procedural guidance for operations and use of the MPS.
- c. Request the establishment of postal support per this manual.
- d. Maintain audit, inspection, advisor, and assistance responsibilities for the MPS activities under their jurisdiction.
- e. Ensure MPA provide routing and dispatch instructions via AMPS when their respective units change location, activate, deactivate, inactivate, commission, decommission or rotate.
- f. Collaborate with MPSA concerning policies and procedures in execution of postal operations.

g. Coordinate International Commercial Air (ICAIR) transportation requirements with MPSA.

h. Establish and operate MPA to meet an operational requirement.

i. Ensure support services (i.e., custodial, utilities, real property maintenance, and transportation) are provided to on-site MPAs on a non-reimbursable basis. This must include providing additional facilities, supplemental transportation, and personnel augmentation in support of local MPAs to eliminate mail backlogs created by emergencies, exercises or seasonal increases in mail volume.

2.5. Office of the Secretary of The Army.

2.6. Combatant Commanders (through the Chairman of the Joint Chiefs of Staff)
Combatant Commanders who have established, and are operating MPAs in their respective theater of operations shall use the following procedures:

a. Appoint a Single Service Postal Manager, as determined by the Combatant Commander.

b. Coordinate planning involving MPS matters within their respective geographical area of responsibility with the Military Services and MPSA.

c. Ensure operational locations have a Host Nation Agreement (HNA) available to facilitate MPS establishment.

d. Specify any restrictions for prograde and retrograde postal.

e. Provide MPS support.

f. Request initial opening and the last closing of an MPA in any country.

g. Assign and transfer operational control of MPAs to and between Service Component Command (SCC).

h. Ensure sharing of resources between the SCC to avoid duplication of expenditures and effort, to include providing military air and surface transportation support to move mail when tendered by the USPS or MPS.

i. Manage the postal processing, transportation, and distribution operations throughout their Areas of Responsibility (AOR) and integrate their SCC's control of military mail movement within the theater. Coordinate with Joint Military Postal Activity (JMPA) on transportation operations.

j. Establish and manage a theater IDS Recovery Center for frustrated IDS type items.

- k. Request and manage Free Mail for their respective AOR.

2.7. Executive Director of the MPSA.

- a. Perform functions as listed in the DoDD 5101.11E and the DoDI 4525.09.
- b. Maintain liaison with strategic partners with respect to the security, processing, transportation, and distribution of postal items.
- c. Coordinate screening and restriction of postal items based on input from OGA.
- d. Provide the Military Services a Postal Voting Action Plan.

2.8. Joint Military Postal Activity (JMPA).

- a. Serve as the single point of contact to coordinate efficient processing, dispatch, transportation, and distribution of military mail at designated USPS airport gateways and provide feedback to USPS, airlines, and the MPS stakeholders on irregularities (e.g. Military Distribution Table Management System and Absentee Ballots).
- b. Coordinate shipment of surface (sea) containers for prograde and retrograde postal and empty equipment.
- c. Process and fulfill MPA supply and equipment requests.
- d. Maintain PS Form 1590 in AMPS for hand receipt holders from each MPA.
- e. Coordinate with USPS Office of Inspector General (OIG) and the United States Postal Inspection Service (USPIS) on suspected mail crimes.

2.9. Service Component Command (SCC). (Service Component Commands who have established, and are operating MPAs shall use the following procedures:)

- a. Appoint a senior postal representative to manage postal operations.
- b. Ensure infrastructure and resources are provided to perform the MPS mission.
- c. Integrate mail industry technologies that will improve mail processing and efficiency within postal plans, policy, procedures, training, doctrine, and contracts.
- d. Provide detailed postal policy and procedural guidance for the operation and use of the MPS.
- e. Provide the MPSA with information concerning postal restrictions or policies within the SCC's area of responsibility affecting the MPS.

- f. Provide Subject Matter Expert (SME) support to Contracting Officer during contract development involving postal support or operations.
- g. Develop and publish a Continuity of Operations Plan (COOP) IAW DoDI 3020.42. Identify and manage risk to COOP plan using mission assurance construct found in DoDD 3020.40 and DoDI 3020.45. Include Operations Security (OPSEC) considerations IAW DoDD 5205.02E.
- h. Ensure MPAs maintain a locally developed and approved COOP.
- i. Ensure OPCs incorporate security screening procedures for alternate worksites, telework and remote work locations within the postal support activities COOP, pursuant to FMR 102-192.
- j. Ensure MPAs develop, publish, and fund Facility and Equipment plans.
- k. Conduct annual inspections and ensure audits are completed.
- l. Request activation and deactivation of military ZIP Codes.
- m. Maintain liaison with host nation postal administrations and with postal officials of coalition forces.
- n. Develop mail transportation requirements and coordinate with MPSA.
- o. Ensure all bar-coded items are scanned and input into AMPS.
- p. Ensure MPA are equipped with dedicated commercial or military broadband Internet and telephone circuit to operate and interface with postal equipment.
- q. Provide support to other Military Services or agencies upon coordination through use of a Memorandum of Agreement (MOA) or MOU.
- r. Ensure MPA are postured to process and dispatch absentee ballots.
- s. Coordinate postal personnel access to all mail handling facilities, ramps, and flight line areas as well as equipment and transportation conveyances to conduct surveys and inspections concerning mail movement.
- t. Ensure Postal Net Alerts (PNA), irregularities, and postal reports are reported in AMPS.
- u. Ensure MPAs provide mail directory service.
- v. Utilize media outlets to provide customer service information.
- w. Identify deficiencies in the MPS and take corrective action.

- x. Coordinate with JMPA and provide information for mail routing.
- y. Attend installation real estate master planning meetings.
- z. Provide SME support to Facility Engineers during design, development, and modifications to postal facilities.
 - aa. Identify, consolidate, and monitor postal equipment and supply requirements.
 - bb. Notify MPSA of mail covers.

2.10. Military Mail Terminal (MMT).

- a. Sort and distribute postal items.
- b. Resolve issues on commercial and military modes of transportation.
- c. Maintain safe and secure facilities to protect postal effects and items.

2.11. Commanding Officer (CO) Responsible For Postal. (At the installation-level)

- a. Designate in writing an E7 or above; or civilian equivalent for: Postal Officers, and/or MPO Supervisors.
- b. Designate in writing an OPM and Assistant Official Postal Manager (AOPM).
- c. Ensure that minimum space and structural requirements are met within funds availability and proper programming actions incorporated into the facility plan. Reference Section 15 of this manual.
- d. Ensure dedicated commercial broadband Internet and telephone circuit, to operate and interface with postal equipment.
- e. Provide additional facilities and supplemental transportation to support the unimpeded and timely movement of postal items.
- f. Provide personnel augmentation and equipment when necessary.
- g. Provide safes and secure storage facilities to safeguard registered mail and postal effects.
- h. Plan, program/budget for postal training, equipment, facility upgrades, and other operational costs at the local level.
- i. Ensure external taskings for resources and personnel do not negatively impact postal services.

2.12. Postal Officer or MPO Supervisor.

- a. Appoint postal personnel assigned mail handling duties at MPAs on a Designation Letter of Appointment.
- b. Appoint a temporary COPE in the absence of the COPE greater than five days and less than 31 days.
- c. Appoint a primary and alternate registered postal clerk, and a primary and alternate supply clerk in writing.
- d. Ensure personnel assigned to postal duties have completed required training and acknowledged their role in protecting the security of the mail in writing prior to designation.
- e. Ensure a trained alternate Postal Clerk (PC) is available at one-person MPO locations.
- f. Where approved for registered mail services, establish a registered mail section, and controlled areas for supplies and equipment.
- g. Ensure security, protection of postal items, postal effects, and restrict access of work areas to authorized personnel. Institute additional security measures as necessary.
- h. Report circumstances relative to the destruction of mail and postal equipment via AMPS Postal Report. Clearly describe the details of the incident and be sure to include the type of mail or equipment destroyed, and amount destroyed.
- i. Coordinate postal support to other DoD Components receiving mail support through a postal facility.
- j. Route all postal-related correspondence for higher headquarters through the SCC Postal Representative.
- k. Coordinate with their SCC Postal Representative before entering a support agreement for postal support.
- l. Maintain mail directory service.
- m. Develop and maintain a current Standard Operating Procedure (SOP).
- n. Conduct periodic, unannounced inspections of Consolidated Postal Rooms (CPR), Postal Service Centers (PSC), Unit Postal Rooms (UPR) and mail-handling areas.
- o. Notify appropriate command levels immediately of all postal offenses, PNA, and losses.
- p. Ensure the USPS equipment is used only for its intended purpose.

- q. Ensure hours of operation are posted and visible.
- r. Ensure current copies of publications and visual aides are readily available or posted in plain view for use by postal patrons.
- s. Provide initial and annual refresher training for mail handling responsibilities.
- t. Update MPO profile information in AMPS (i.e., Basic Information, Points of Contact, etc.) as required and verify annually; recommend annotating on regular internal inspections.

2.13. Official Postal Manager (OPM).

(Pursuant to operations under assigned purview of responsibility)

- a. Are appointed at the DoD, department/staff agency, command/region and installation/activity-levels and serve as the single-point of contact for all DoD OM related matters.
- b. Provide management and oversight of the OMP for the Military Components and DoD agencies, compliant with USPS, GSA and DoD policies.
- c. Develop, and provide guidance to ensure efficient integration and implementation of uniform OMP policies and procedures to the Military Components and DoD agencies.
- d. Ensure OPCs incorporate security screening procedures for alternate worksite and telework locations within the COOP, pursuant to the FMR 102-192.
- e. Verify and ensure all subordinate-level OPMs, and those performing OM duties complete DoD Official Postal Managers Training annually in AMPS or Service / Agency equivalent training.

2.14. Postal Finance Officer (PFO).

- a. Requisition adequate quantities of stamps, money orders, equipment, and supplies to meet the requirements for regional locations (multiple COPE/SCs) supported.
- b. Receive and account for stock from the Stamp Fulfillment Service.
- c. Maintain accountability records and supply related forms IAW applicable regulations, publications, and internal and external correspondence.
- d. Are responsible to maintain control and accountability of MPSA and USPS equipment listed on the activity's PS Form 1590.
- e. Monitor requisitions and transmittal of postage sales, money order, and meter business.
- f. Develop and implement field accounting procedures and local SOPs for contingency operations.

g. Conduct and submit audits and resolve financial issues with USPS Finance and Accounting Services in a timely manner.

h. Prepare and conduct training on all aspects of postal finance, supply, and postal equipment management procedures.

2.15. Custodian of Postal Effects (COPE) / Stock Custodian (SC).

a. Requisition sufficient quantities of stamps, money orders, equipment, and supplies to meet the requirements of locally assigned facilities and PCs supported.

b. Receive and account for stock from Stamp Fulfillment Service, or PFO.

c. Maintain accountability records and supply related forms IAW applicable regulations, publications, and internal and external correspondence.

d. Maintain control and accountability of MPSA and USPS equipment listed on the activity's PS Form 1590, as well as operational supplies.

e. Monitor requisitions and transmittal of postage sales, money order, and meter business.

f. Develop and implement accounting procedures, and local SOPs for contingency operations.

g. Conduct and submit monthly audits of PCs and resolve financial issues with USPS Finance and Accounting Services in a timely manner. Ensure all USPS stock deficits are reconciled prior to new FY (NLT September 30).

h. Prepare and conduct training on all aspects of postal finance, supply, and postal equipment management procedures.

i. Ensure daily and quarterly payment card processing equipment inspections are completed as required by the payment card industry and USPS financial regulations.

2.16. Postal Clerk (PC).

a. Provide postal service and operate the MPO.

b. Perform retail duties, maintain stamp stock and cash account, and resolve deficiencies IAW USPS F-101.

c. Safeguard postal items and equipment.

d. Perform directory service.

e. Maintain supply and equipment section.

- f. Operate a registered mail section.
- g. Process postal items for patrons serviced by the MPA.
- h. Deliver accountable mail and maintain accountable mail records.
- i. Report known or suspected postal and offenses to the next level in the chain of command.

2.17. Hand-Receipt Holder (HRH).

- a. Signs for and maintains security and accountability of all postal equipment at a MPA location where a COPE/SC is not permanently assigned (i.e., Postal Annexes, equipment user, etc.).
- b. Ensure postal equipment previously hand receipted is returned (physically and/or administratively) to the responsible COPE/SC prior to departing respective roles/responsibilities.

2.18. Tenant Commander.

- a. Designate in writing a Unit Postal Officer (UPO) or alternate to cover absences of the UPO that exceed more than four days.
- b. Designate in writing UPC and (Unit) Postal Orderly(s).
- c. Provides a separate secure room and equipment to perform UPR functions.

2.19. Unit Postal Officer (UPO).

- a. Attend required mail handling training within 30 days of designation.
- b. Ensure postal clerks attend required mail handling training.
- c. Notify the local servicing post office of upcoming deployments and provide necessary instruction regarding unit requirements.
- d. Conduct weekly unannounced random inspections of UPR.
- e. Verify the delivery of official accountable mail.
- f. Follow applicable regulations, manuals, and other directives relevant to the performance of postal duties within this manual.
- g. Report known or suspected postal offenses to the servicing MPA.

2.20. Unit Postal Clerk (UPC).

- a. Attend required mail handling training within 30 days of designation.
- b. Pick up mail daily from servicing post office.
- c. Deliver mail to addressee or authorized agent.
- d. Provide mail service and operate a UPR or Consolidated Postal Room (CPR).
- e. Safeguard the postal items at all times.
- f. Perform directory service.
- g. Deliver accountable mail and maintain accountable mail records.
- h. Report known or suspected postal offenses to the UPO.
- i. Match articles found loose with their original envelopes or wrappers and return unmatched articles to the servicing MPO.
- j. Return undeliverable mail to the servicing MPO daily if the activity does not meet the structural requirements.
- k. Follow applicable regulations, manuals, and other directives relevant to the performance of mail handling duties within this manual.

2.21. (Unit) Postal Orderly.

- a. Must be appointed and sign a Statement of Understanding regarding mail handling duties.
- b. Attend required mail handling training within 30 days of designation.
- c. Pick up mail from the servicing UPR, CPR / PSC, or MPO daily at the specified times.
- d. Safeguard the postal items at all times.
- e. Deliver personal mail only to the addressee or authorized agent.
- f. Return undeliverable mail to the servicing UPR, CPR / PSC, or MPO daily.
- g. Report any known or suspected postal offenses and irregularities to the UPC or UPO.
- h. Match articles found loose with their original envelopes or wrappers and return unmatched articles to the UPR or servicing post office.
- i. Follow the applicable regulations, manuals, instructions, and other directives relevant to

the guidance outlined within this manual.

SECTION 3: ADMINISTRATIVE

3.1. Exceptions to Policy (ETP). (Relating to postal matters.)

a. Submit exception to policy (ETP) through the chain of command through MPSA to the Under Secretary of Defense for Acquisitions and Sustainment USD(A&S) for approval.

b. For ETP requests to be actioned by MPSA and submitted to USD(A&S) for review and approval, include the following agency/command levels review and coordination:

(1) Request for ETP must be sent through the chain of command and endorsed by a flag officer, prior to submission to MPSA who will endorse the packet recommending approval/disapproval and send to OSD for decision.

(2) If not specifically allowed by the current HNA or Status of Forces Agreement (SOFA), request must include diplomatic correspondence allowing the patron or group to receive MPS support.

(3) SCC legal team will provide a legal review of the postal support requests, and this will be sent with the packet through the chain of command through MPSA to OSD.

c. The following six criteria must be met for granting of an ETP:

(1) It will assist substantially in, or is essential to, the accomplishment of the US government mission.

(2) It must be allowed by the HNA or SOFA; the relevant sections of the HNA or SOFA must be included in the package sent through the chain of command through MPSA to OSD.

(3) It will not place the privileges and immunities of US armed forces in jeopardy.

(4) It will not increase the resource requirements of the MPS activity. If the ETP is granted, any future resource constraints may cause termination of the support.

(5) There is no USPS facility or international postal service available in the area.

(6) It will not result in the US government assuming any costs.

d. Exceptions are temporary in nature and should be rare occurrences to mitigate location specific circumstances, contrary to operational standardization across DoD.

3.2. International Exchange Office (IEO).

a. USPS approval is required to establish an IEO

b. An IEO at overseas military postal activities circumvents Universal Postal Union

conventions and host nation customs increasing risks of dangerous or contraband item introduction into the MPS.

c. Approved postal activities will only exchange missent official letter class mail (LCM) or personal LCM.

d. IEOs will not be used to:

(1) Circumvent the normal international mail process.

(2) Send directory mail to an international address.

(3) Accept or receive business bulk mailings or any parcels for distribution to MPS patrons.

e. Postal items that are prohibited from passing through the IEO will be sent to the USPS International Service Center (ISC) for onward movement to the intended international destination.

f. Official LCM coming from the host nation should be visually screened for indicators of suspicious mail per USPS Poster 84 (Suspicious Mail or Packages).

g. Sufficient host nation postage will be applied to OM between DoD officials and host nation to ensure auditability and mitigate Universal Postal Union violations and delivery issues.

3.3. Standard Operating Procedures (SOP). MPAs will develop Standard Operating Procedures (SOP) that will include information that is unique or has significant impact on the operation.

3.4. Military Postal Service Procedures Manual (MPM) Governance.

a. Governance.

(1) Changes to the MPM are published quarterly. However, changes in the law, and U.S. Code; as well as USPS, DoD and GSA policy may compel changes to the MPM to occur at any time.

(2) Change Suggestions to the MPM must be submitted through AMPS. However, changes which require immediate implementation will not be processed through AMPS. These changes will be released to the MPS enterprise via AMPS Message to users and incorporated into the next scheduled MPM version release.

(3) Each version of the MPM will contain a Summary of Changes page, whereby changes to the previous version are outlined. Throughout the manual, new changes will be highlighted in blue font for ease of reference. With each subsequent version of the manual,

previous changes highlighted in blue will change to black, and new changes listed on the Summary of Change page will be highlighted in blue font throughout the manual.

b. Suggested Change Evaluation, and Approval Process:

(1) Phase One – Initiate MPS Publication Suggestion in AMPS. (Users submits suggestions to MPS publications when circumstances are identified which fail to meet legal or regulatory requirements, and/or properly address operational procedures associated with MPS enterprise)

(a) The MPS Publication Suggestion Module is located at: <https://amps.usps.gov/> (Knowledge Management→Policy→Publication→Suggestion)

(b) Any AMPS User may submit a publication suggestion. AMPS users will:

1. Utilize a succession of aggregating menus to provide organization and MPA information. In addition, use a series of aggregating menus to provide the MPS publication, section, paragraph (figure or appendix), and line applicable to the suggestion.

2. Provide a detailed description surrounding the circumstance, or requirement (need) to which the suggestion relates. Include a recommendation, and detailed justification to include supporting references, risk or vulnerabilities if left unchanged, and positive impact if the suggestion is adjudicated/approved.

3. Quality control all information provided in the suggestion, and then submit. Once submitted, the suggestion will automatically forward, to Phase Two, Discussion, Evaluation, and Recommendations in AMPS.

(2) Phase Two – Discussion, Evaluation, and Recommendations. (A comprehensive, multi-faceted evaluation is conducted for each suggested change, and the SCCs and DoD Components provide discussion inputs, recommendations and justification.)

(a) SCC/Defense Agency or Field Activity POCs:

1. Appoint primary and alternate POCs, and request access permissions in AMPS through MPSA, Plans and Policy Division to review, evaluate and action suggestions.

2. Conduct an evaluation based on multiple factors (not limited to): compliance with Host Nation Agreements, country restrictions for mail, and the operational environment.

3. Provide a support recommendation, and justification.

(b) MPSA Division Chiefs conduct an initial review of the suggestion and evaluate compliance with law, as well as USPS, GSA, and DoD policy. In addition, MPSA will:

1. Coordinate (when necessary) with internal and external agencies, as well as USPS in support of research analysis.

2. Evaluate suggestions for merit in their entirety, or in part; and provide recommendations accordingly.

3. Document all evaluation and research in AMPS, as well as provide a support recommendation, and justification.

(c) The MPS–Publications Review Board (MPRB), made up of appointed members (x2) of the Office Under Secretary of Defense for Acquisition and Sustainment, MPSA Division Chiefs (chairman), Joint Staff, Combatant Commands, Military Department Postal Program Managers, Defense Agencies, and DoD Field Activities will:

1. Maintain an active AMPS account, and access to the MPS Publication Suggestion and Review module in AMPS. New (and replacement) members coordinate access through MPSA, Plans and Policy Division.

2. Conduct a thorough review of the suggestion, provide discussion and research inputs, a support recommendation, and justification.

(d) Suggestions must be actioned within seven calendar-days from the date a suggestion enters Phase Two. Agencies having failed to action a suggestion will be recorded in AMPS as “Not Actioned by SCC/Agency.”

(e) After seven calendar-days, suggestion will automatically transfer to Phase Three, Proposals and Recommendations.

NOTE: Appointed members must be authorized to speak on behalf of and represent the interests of their department/organization/agency.

(3) Phase Three – Proposals and Recommendations. (Military Department Postal Program Managers and MPSA Division Chiefs review Phase Two evaluation information and provide decision-inputs, optional proposals, and an adjudication recommendation)

(a) Members assigned to this Phase provide (a record) proposals and their official adjudication recommendation with justification to support their election. Proposal may be based on the suggestion’s merit, whether in its entirety, or in part.

(b) Changes involving the law, U.S.C., international agreement, USPS directives, Postal Regulatory Commission, and other Federal regulatory organizations, are subject to legal review. After seven calendar-days from the date a suggestion enters Phase Three, suggestion will automatically transfer to Phase Four, Adjudication Determination.

(4) Phase Four – Adjudication Determination. (The MPS Publication Suggestion and Review, Program Manager validates and prepares suggestion review and evaluation system data for Interim-Change Authority (ICA) consideration)

(a) Program Manager will:

1. Prepare the Adjudication Determination package by including formatted data elements submitted during Phase One, Two, and Three of the suggestion evaluation process in AMPS. The package will include:

a. The original suggestion, input discussion, evaluation results, support recommendations, (optional) proposals, and recommendations; in a structured breakout of each phase.

b. An Adjudication Determination Memorandum for the ICA to approve or deny suggestion adjudication proposals/recommendation by Military Department Postal Program Managers and MPSA Division Chiefs in Phase Three.

2. Route the Adjudication Determination package to the ICA for consideration.

(5) Phase Five – Suggestion Disposition. (The MPS Publication Suggestion and Review, Program Manager will quality-control and action the suggestion, IAW the ICA's determination)

(a) Approved suggestions will be drafted and incorporated into the next scheduled MPM version release. All suggestion files will be archived in AMPS for historical purposes. Refer to Appendix 38A (this manual) for specific record retention instructions.

(b) Denied suggestions will be closed, and [files] archived in AMPS for historical purposes. Refer to Appendix 38A (this manual) for specific record retention instructions.

NOTE: The ICA maintains the authority to over-ride suggestion determinations made by the MPS Publication Suggestion and Review Process, as prescribed IAW DoDD 5101.11E, and DoDI 4525.09, when determined to be in the best interest of DoD's MPS enterprise.

APPENDIX 3A: MPS PUBLICAION SUGGESTION AND REVIEW PROCESS FLOWCHART



APPENDIX 3A: MPS PUBLICATION SUGGESTION AND REVIEW PROCESS FLOWCHART

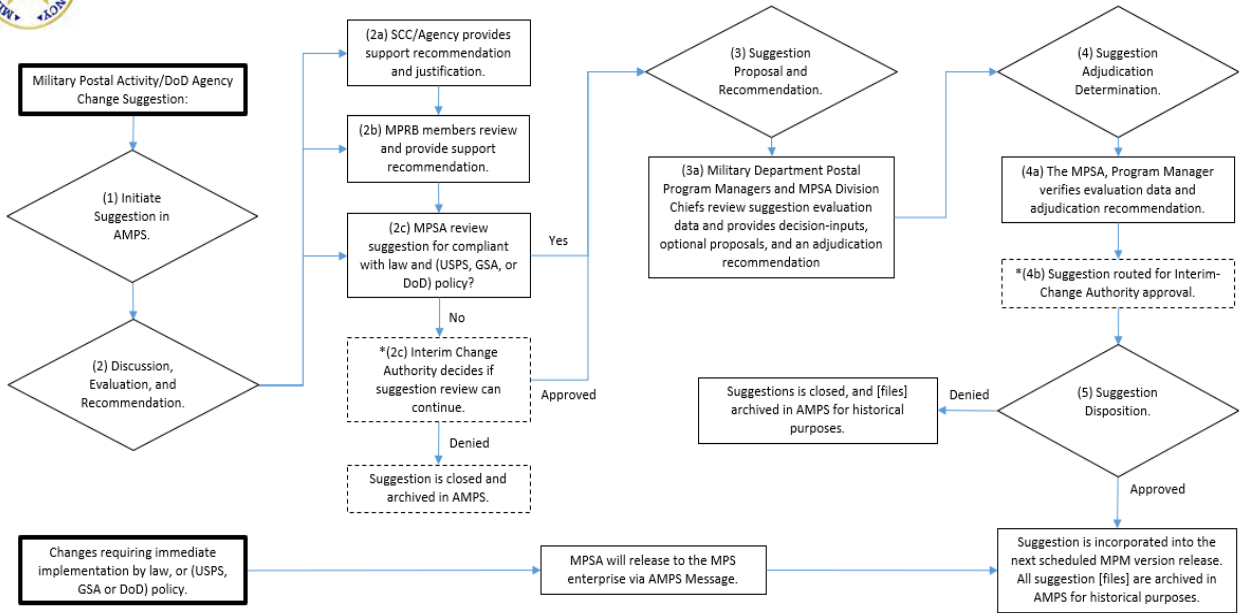

* MPSA maintains adjudication authority of MPRB determinations, IAW DoDD 5101.11E, and DoDI 4525.09., when determined by the Interim-Change Authority to be in the best interest of DoD's MPS enterprise.

SECTION 4: ESTABLISHING AND DISESTABLISHING POSTAL SERVICE

4.1. General. The MPS may only be established in a country after a HNA is in place or when the US is conducting a forced entry operation. HNAs must be coordinated through DoS in country and permit the establishment of the MPS exempt from taxation, duties and fees. The HNA may impose certain limits on postal including patrons supported, items not allowed to be imported and size/weight restrictions.

a. COCOM/Military Services should seek postal support from DoS for short term missions, exercises or unconventional forces.

b. COCOM must submit request to OSD via MPSA for initial opening of MPS in countries under one of the following three scenarios.

(1) Forced entry - No HNA required.

(2) Named combat or sustainment operations.

(3) Unnamed peacetime operations.

c. COCOM/SCC provides one copy of the HNA, local legal review, and any other agreements that authorizes the establishment to MPSA.

d. COCOM/SCC submits MPA requests in AMPS.

e. MPSA coordinates with USPS to establish MPS and the transportation network.

f. SCC requisitions essential supplies and equipment.

g. SCC identifies the number of personnel to be provided service.

h. SCC ensures postal infrastructure is in place prior to MPO opening.

4.2. Requirement.

a. For peacetime or sustainment operations, COCOM submits a request to establish MPS with a copy of HNA through the JS and MPSA for USD(A&S) approval.

b. For contingency operations, COCOM submits a request to establish MPS with a copy of the HNA through the JS and MPSA for approval.

c. Upon approval of MPS, SCC request establishment of an MPA in AMPS.

d. MPSA will approve or deny MPA requests from the SCC. Not all locations will qualify for its own 5-digit ZIP Code. Approval is based on population served, estimated mail volumes, transportation, and proximity to existing MPAs.

(1) Unit Finance Numbers are requested via AMPS by the respective SCC for new or established MPAs to initiate retail services.

(2) SCC will submit a Supply Management International Transportation Request (SMITR) to MPSA-TR, for (new or existing) geographical location when no transportation lane exists.

(3) MPAs will request a Federal Standard Requisitioning and Issue Procedure (FEDSTRIP) Account Number to order USPS equipment and supplies.

e. The request for establishment of a MPO in areas where USPS operates will be submitted in writing by the Service to MPSA. The request must meet at least one of the following criteria:

(1) Augmenting the USPS for short periods when unusual circumstances prevail, and USPS cannot provide service.

(2) Assisting in providing postal operations involving maneuvers and field exercises in isolated locations where the USPS cannot provide service.

(3) On-the-job training (OJT) for personnel assigned to military postal units subject to deployment.

f. Approval to operate military training postal units in areas where the USPS operates is necessary for each installation. Authority, once granted remains effective indefinitely at the installation, provided:

(1) The installation retains the mission to train military postal personnel.

(2) Personnel selected to conduct such training are qualified members of the MPS.

g. MPO disestablishment:

(1) SCCs will disestablish or reclassify MPO in AMPS.

(2) SCCs/MPAs will request disposition instructions from the appropriate JMPA to turn-in and clear all postal equipment listed on the activity's PS Form 1590; as well as excess supplies maintained in the activity's Supply Program. Discrepancies should be resolved prior to the closure. Unresolved discrepancies should be referred to MPSA for action.

(3) MPO will request redirect surface mail at the gateway 45 days prior to base closure.

(4) MPO provide patrons with at least a 60-day termination notice. Notify JMPA for mail redirect 30 days prior to closure.

(5) Coordinate Mobile Routing Instructions (MRI) for all units relocating. Coordinate

and publicize closure of MPO and PSC(s) to coincide with drawdown of personnel. Reduce services as mission dictates.

(6) Transfer active postal offense case files to the designated MPO.

(7) Transfer money orders, stamp stock, and meters as appropriate. SCCs will provide additional guidance.

(8) Coordinate disposition of mail receptacles and accountable equipment.

(9) Appoint an official to conduct audits.

(10) Conduct an audit of accountable postal effects, including equipment, at the close of business on the last day of operation or within five working days.

(11) Perform disposition of accountable records IAW with the appropriate USPS, DoD or SCC disposition instructions, as applicable.

SECTION 5: POSTAL DEPLOYMENT PLANNING

5.1. General.

a. Postal operations and services impact morale. Postal item volume may strain theater postal and logistics assets; therefore, postal items should be processed, transported, and delivered as a joint operation. Consider using the host nation's postal infrastructure to provide postal support to DoD personnel.

b. Close coordination and communication with personnel and logistics planners for dedicated air transportation, ground transportation, early deployment of postal forces, palletization crews, container moving and lifting equipment, specialized postal equipment, and sufficient in-theater postal facilities are critical to successful MPS operations planning and mission accomplishment.

c. COCOMs must consider postal support for various types of operating environments ranging from austere locations where infrastructure is nonexistent to robust locations where permanent facilities are available.

d. The MPSA coordinates with the USPS on operational decisions regarding sorting, disposition, transportation, requisitioning supplies and equipment, security and screening of the mail, and restriction of mail to mitigate impacts on the MPS.

e. COCOMs may request a temporary ZIP Code suspension from USPS via MPSA. A temporary ZIP Code suspension may be considered for the following reasons:

- (1) Transportation availability.
- (2) Storage space.
- (3) Tactical situations.
- (4) Personnel staffing.

f. COCOMs may submit a request for restrictions and MPSA will forward the request to the USPS. COCOMs may restrict mail by class, weight, or contents. A restriction may be considered for any of the following reasons:

- (1) Transportation availability.
- (2) Storage space.
- (3) Host Nation restrictions.
- (4) DoD General Orders

g. DoDI 4525.09 identifies requirements for Free Mail (FM) approval/authorization. COCOM postal plans shall provide procedures for requesting FM.

h. Retail services are normally an integral part of postal operations. However, when situations dictate (for example, during high-intensity combat operations or short-term deployments), MPS retail services may be curtailed, suspended, or not provided at all.

i. The requirement for trained personnel is based on total population served, postal services required, and geographic location of the supported units.

j. Navy afloat MPS operations will not include Marine Corps population in the calculation of postal finance support.

5.2. Requirement.

a. Planners must ensure that an HNA/SOFA is in place during the planning prior to commencement of MPS operations. Forward a copy of the agreement to MPSA. In a Forced Entry operation, an HNA/SOFA is not required.

b. Develop Postal Facilities to accommodate mail volumes equal to 1.75lbs per patron per day.

c. CCDRs should identify point of entry for air transportation and surface containers and notify the MPSA.

d. MMTs should plan for one trained PC per 1,500 personnel supported.

e. MPOs should plan for one trained PC per 500 supported personnel during initial operations (30 days); one additional per 500 for sustainment operations up to 10,000 personnel; and one per additional 1,000 personnel thereafter. MPO's should have a minimum of one customer service window per 2000 population served.

f. Minimum of two PC are required at deployed locations.

g. Joint MPAs will use a pro-rata Service PC allocation process to ensure fair workload representation based on the population served.

h. Commanders must determine the flow of postal personnel into theater to ensure the MPS is in place prior to the start of mail flow.

i. Postal equipment must be integrated into the Time Phased Force Deployment Data list to support the timely flow of mail into the operational area. Equipment should include items such as: trucks, containers, container handling equipment, forklifts, pallet jacks, and postal pre-pack sets.

j. Ensure dedicated commercial broadband Internet and telephone circuit, to operate and

interface with postal equipment.

k. Military Services must ensure that logistic requirements and pre-pack inventories are periodically reviewed and updated. Identify pre-positioned assets to support mail terminal operations.

l. COCOMs will designate responsibilities for establishing and providing postal support.

m. COCOMs will submit FM requests to USD(A&S) via MPSA and JS.

n. FM requests will include the following:

(1) Recommended location for FM designation and justification.

(2) Estimated number of personnel to be served to include the Military Service and DoD civilians, as well as hospitalized Service members as defined by Section 101 of Title 10, U.S.C.

(3) Estimated date when an MPO will be established.

o. Notify the MPSA of planning resource shortfalls. MPSA will not allow mail flow until adequate resources are in place to ensure timely, unimpeded mail flow.

APPENDIX 5A: POSTAL PLANNING CHECKLIST

5A.1. Continuous Planning.

a. The CCDR/SCC ensure a HNA/SOFA is established for countries in the area of responsibility prior to receiving deployment orders. Agreements may be Diplomatic Notes, SOFAs, Defense Security Cooperation Agreements, or MOAs as an example. If no agreement exists, coordinate with CCDR country team to request unrestricted mail operations in the host nation including mail free from customs duties and taxes. A HNA/SOFA is not required for forced entry military operations.

b. The SCC will:

(1) Maintain a strategy to posture personnel and resources for deployment.

(2) Ensure postal personnel are trained and equipped to perform postal duties in a contingency environment. Training should include Eagle/Navy Cash processing procedures, or similar systems used for postal retail transaction.

(3) Maintain equipment and supplies to support operational plans, and establish pre-packs.

(4) Submit ETP requests through CCDR to MPSA for review and OSD approval.

5A.2. Pre-deployment.

a. The CCDR will:

(1) Ensure postal support planning is included in operations exceeding 90-days and coordinated with the Military Services. Usually operations less than 90-days will not include postal support unless co-located with an existing MPO. Consider mail makeup restrictions to allow the postal processing network to mature (i.e., Sustained air and ground transportation, infrastructure of designated facilities, effectiveness mail-flow, efficient handling processes and appropriate staffing).

(2) Determine need to establish a joint postal cell or appoint a single-service postal manager to coordinate and oversee postal operations. If either are established, they serve as an extension of, and in coordination with the CCDR.

(3) Submit requests for suspensions of mail service to MPSA.

(4) Assign postal responsibilities when operations in theater include multiple Service.

(5) Submit requests for Free Mail to MPSA. If approved, MPSA will provide implementing instructions.

(6) Coordinate with MPSA and the SCC to:

(a) Determine airport and seaport capability and availability.

(b) Coordinate with MPSA and submit a Supply Management International Transportation Request for commercial air transportation contracts. Determine/consider application for military airlift (i.e., Registered Mail).

(c) Determine air or ground logistics support to transport postal items.

(d) Establish postal movement within theater for all Services, if door-to-door transportation is unavailable.

(e) Determine postal facility size. Consider total population served, projected volume, MPA security, postal processing equipment layout, staging requirements for mail, postal effects, supplies, and equipment including empty equipment. Availability of facilities will influence these planning factors. The following data provides a baseline for initial planning:

Figure 5A – Mail Attribute Planning Factors

LCM/FMS	Quantity	Average Weight	Count Per Tri-Wall
Letters (Ltr)	1 Ltr/Person/Day	13 oz/Person/Day	18,000
Flats (per Tub)	~45	3 kgs	630
Parcel	1 Parcel/Person/Day	1.75 lbs/Person/Day	~55
Receptacles	Quantity	Average Weight	Count Per Tri-Wall
Letter Tray (Small)	225 (Ltr Per Tray)	1.5 kgs	72
Letter Tray (Large)	500 (Ltr Per Tray)	3 kgs	36
Tubs	1	3 kgs	14
Outside Piece (OSP)	1	7 kgs	**
Pouch/Sack	1	10 kgs	~12
Transportation Containers	Quantity	Average Weight	Measurements
Tri-Wall	1	125 kgs	L-49", H-34 1/2", W-35 1/2"
Per 20 ft. Sealand (Tri-wall Loaded)	20-Double Stacked	2500 kgs	L-19' 4", H-7' 10", W-7' 9"
Per 40 ft. Sealand (Tri-wall Loaded)	40-Double Stacked	5000 kgs	L-39' 4 3/8", H-7' 2 1/2", W-7' 7 3/4"
20 ft. Sealand (Loose Loaded)	285 - Pieces	2,422 kgs	**
40 ft. Sealand (Loose Loaded)	600 - Pieces	4,920 kgs	**

** Non-applicable, or variables to the data-point prevent consistent and credible tracking.

(f) Develop and distribute mail routing, labeling, massing, and consolidation-point instructions to support efficient and sustainable mail flow.

(g) Provide the SCC with mail-screening guidelines as needed.

b. The SCC will:

(1) Determine initial postal and augmentee personnel requirements. The following recommended factors provide a baseline for initial planning:

(a) COPE = one per MPA.

(b) Postal Clerk = one per 500 personnel supported/>10,000 = one per additional 1,000 personnel supported.

(c) MMT/ Mail Control Activity (MCA) personnel = one trained clerk per 1,500 personnel supported.

(d) Augmentee personnel = as determined by the SCC.

(2) Determine initial postal and administrative equipment requirements:

(a) Computers (i.e., workstations and/or laptops).

(b) RSS terminals and/or meter and scale equipment (i.e., OPC, satellite locations, etc.).

(c) Eagle/Navy Cash equipment.

(d) Communication (i.e., voice and internet) capability requirements.

(e) Product Tracking and Reporting (PTR) scanning equipment.

(f) Postal equipment. (i.e., cancelling machines, sorting tables and bins, conveyors, shelving)

(g) Vehicles.

(h) Facility (i.e., tents and CONEX's where structures do not exist).

(3) Coordinate postured personnel and resource requirements (Validate time phased force deployment list [TPFDL] for deployments).

(4) Propose levels of service, size and weight restrictions to the CCDR; as well as existing host-nation limitations/restriction where/when applicable (CCDR provides to MPSA).

(5) Coordinate/request ZIP Code assignment from MPSA via AMPS, request includes:

(a) ZIP Code (do not activate via USPS), include CCDR coordination if needed.

(b) Standard Field Accounting (SFA) Number.

(c) Finance Number.

(d) FEDSTRIP Number.

(6) Request (by MPA location) through MPSA, the required RSS terminals, postage-meter and scale systems, and Eagle/Navy Cash equipment.

(7) Ensure Global Trade Compliance (GTC) requirements are established in all MPA operations.

5A.3. Deployment.

a. The contingent of MPA personnel will:

(1) Contact POC to coordinate and secure designated MPA facility (i.e., tent or temporary facility in austere locations).

(2) Contact respective POC to identify and coordinate power, voice and computer connectivity requirements (both DoD network and commercial internet access for USPS equipment).

(3) Contact motor pool/Logistics Readiness to coordinate vehicles.

(4) [MCA/MMT personnel] contact commercial/military airport POCs:

(a) Customs Officials (US and local host-nation) to determine and comply with local requirements and restrictions.

(b) Airport Security (commercial/military) for badging and permit requirements for personnel and vehicles and identify established mail screening procedures.

(c) Carriers (i.e., facility location, POC's, carrier meetings).

(d) Ground-handler (i.e., rally-points, spot-times for mail exchange).

(e) Identify site/Service specific (ZIP Code) sortation requirements.

(5) Identify personal and OM unit address (ZIP + 4) sortation requirements.

(6) Contact local host-nation postal POC(s) to coordinate and secure designated pick-up facility and mail exchange procedures. Formal requests to establish an International Exchange Office are submitted by the CCDR/SCC to MPSA. MPSA coordinates request with USPS (review and approval). If approved, MPSA will provide implementing instructions.

b. The SCC will:

(1) Coordinate request for MPSA to “activate” ZIP Codes when postal personnel and facilities are in place and the transportation network is established.

(2) Coordinate official release of personal and OM addresses, mail routing, labeling, massing, and consolidation point instructions for all units throughout postal community.

(3) Establish inspection, audits and staff assistance visit schedules.

(4) Provide election material and ballot handling procedures to MPAs and monitor processing compliance.

c. The MPA will:

(1) Establish operations and procedures with equipment on hand to begin processing postal items and retail sales services. Initial operations are limited; recommend the following mail flow:

(a) Initial postal service will commence approximately no earlier than 30-days from the date the SCC submits the ZIP Code “activation” request through MPSA to USPS. Once received, USPS will initiate a retail and logistics system update to propagate all (USPS/military) retail and acceptance activities.

(b) During this time, the MPA will validate (internal/external) postal support and operational processes, and verify logistics infrastructure (i.e., transportation, facilities/equipment, and postal personnel) to ensure full-service sustainment and network maturity.

(2) Determine privilege-levels of temporary and permanent patrons based on location, size, and capability.

(3) Establish procedures to support:

(a) Receipt and dispatch.

(b) Unit mail call.

(c) Postal finance services: money orders, postage stamps, mailing packages.

(d) Electronic Funds Transfer capability for remittance.

(e) Ordering and management of USPS postal stock (i.e., stamps and money orders), OM (meter) postage, and general postal/mail processing supplies.

(f) Acceptance, delivery, and storage of mail with special services.

(g) GTC in required sections of all MPA operations.

(h) Official Mail operations.

(i) Election material and ballot handling.

(j) Casualty mail section.

(k) Directory including home station and deploying unit's information.

(l) Handling suspicious/contaminated postal items.

(4) Establish data collection procedures for monitoring postal operations such as:

(a) Weights and piece count for mail received or dispatched.

(b) Postage sales/revenue (i.e., stamps, meter tapes issued).

(c) Transit time to and from the U.S.

(5) Establish self-inspection and audit schedule.

(6) Coordinate with the SCC to ensure SOPs provide detailed instructions for each functional area of postal operations not specifically covered by the USPS or DoD Regulations and Directives. At a minimum, SOP will include information that is unique or has significant impact on the operation, to include:

(a) Key points of contact.

(b) Alternative operation sites.

(c) Contingency procedures.

(d) Resource protection.

(7) Establish an evacuation plan for mail when postal facilities are threatened requiring permanent or temporary relocation of the postal facility including:

(a) Change of address notification.

(b) Requests to MPSA to divert or embargo mail.

(c) Mail handling when sufficient/insufficient advance warning is received.

(d) Emergency destruction of postal effects. (Refer to Section 8.1.h.)

(8) Initiate requests for mail support associated with foreign forces, foreign nationals supporting US forces and United Nations (UN) through the SCC and CDR, to MPSA for review/approval.

(9) Initiate and forward proposals for contracting postal service (based on mail support plan) and/or host nation postal support requests through the SCC and CDR, to MPSA for review/approval.

(10) Initiate ETP requests through the SCC and CDR, to MPSA for review/approval.

(11) Submit requests for suspensions of mail service through the SCC and CDR, to MPSA for review/approval.

5A.4. (Re/Post) Deployment.

a. MPA Transfers (Command and Operational Responsibility). The SCCs have important oversight roles during an MPA transfer, and therefore should remain involved throughout the process. SCCs are key in providing guidance, monitoring tasks and mandated timelines, and ensuring compliance with established procedures for an effective and efficient transfer of command authority and operational responsibility.

(1) Pursuant to the transfer, arriving and departing MPA leaders will:

(a) Properly appoint, designate, and terminate MPA personnel commensurate with assigned roles and responsibilities.

(b) Conduct inspections, inventories, and audits jointly with the incoming and outgoing COPE. Include the number and identity of the USPS accountable items, MOs, stamp stock accounts, and postage meter accounts. If a reserve custodian maintains a portion of the stock, they shall participate in the audit.

(c) Conduct a joint inventory of all assigned equipment and supplies; resolve any discrepancies prior to the transfer of the COPE (PS Form 1590) and Supply Program.

(d) Conduct a joint inspection and audit of the Unit Reserve, and all finance clerk accounts assigned IAW the USPS Handbook F-101, Chapter 13 and DoD procedures. If a shortage appears in the Unit Reserve account during the transfer of an account, resolve the shortage before transferring. Refer the matter to the MPSA if not resolved prior to transfer.

(e) Conduct a joint examination of the accountable records management program, and all SOP's associated with functions and processes of the MPA. Provide detailed instructions for each functional area of postal operations not specifically covered by the USPS or DoD

regulations and directives.

(f) Update all MPA (internal/external) related appointment memorandums.

(g) Update the MPA profile in AMPS to reflect current information.

(2) MPA Closure/Disestablishment of Operations (the MPA will):

(a) Coordinate with the SCC through the CCCR to initiate request to close, factoring in at least a 90-day termination notice to customers.

(b) Submit formal closure request to MPSA via AMPS, no later than 30-days prior to requested closure date.

(c) Coordinate with the SCC and gaining MPA for new addresses and mail routing instructions for all units relocating. Submit requests to MPSA via AMPS for approval and system update.

(d) Conduct an inspection and audit of the Unit Reserve, and all finance clerk accounts assigned IAW the USPS Handbook F-101, Chapter 13 and DoD procedures. All discrepancies should be resolved prior to the MPA closure. Refer the matter to the MPSA if not resolved prior to closure.

(e) Follow disposition instructions for money orders, stamp stock, meters IAW the USPS Handbook F-101, Chapters 11 and 13 and DoD procedures.

(f) Conduct an inspection and inventory of all assigned equipment listed on the activity's PS Form 1590, Supplies and Equipment Receipt and operating supplies maintained in the activity's Supply Program; any discrepancies should be resolved prior to the closure. MPAs will coordinate disposition instructions with JMPA for excess equipment and supplies on-hand.

(g) Conduct directory service for all prograde (incoming) [postal](#) 30-days prior the schedule closure date.

(h) Coordinate with the SCC through the CCCR to designate an activity to conduct directory or redirect service for period of 6-months after the closure date.

(i) Reduce services 30-days prior to scheduled closure.

(j) Properly maintain (active and inactive) appointment, designation, and termination files for MPA personnel.

(k) Coordinate with the SCC to perform disposition of accountable records IAW with the appropriate USPS, DoD, or SCC disposition instructions, as applicable.

SECTION 6: MAIL COVERS

6.1. General.

a. Postal items, to include information on the outside of any mail piece, are protected under the provisions of the Privacy Act of 1974. Copying, reproduction or distribution of this information is privacy protected and requires a mail cover, which is part of the investigative process.

b. Postal personnel receiving requests for mail covers from federal law enforcement agencies will be referred to the O-6 and above or civilian equivalent authorized to approve.

c. Mail covers in the MPS apply to all postal items. Specifics will be shown in the mail cover request pertaining to the subject of the investigation. (See APPENDIX 6A: MPS Mail Cover Request)

6.2. Requirement.

a. Mail cover requests shall meet one of the following:

- (1) Protect national security.
- (2) Locate a fugitive.
- (3) Obtain evidence of a commission or attempted commission of a crime.
- (4) Obtain evidence of a violation or attempted violation of a postal statute.
- (5) Assist in the identification of property, proceeds, or assets forfeitable under law.

b. SCC commander responsible for postal will notify MPSA of approved mail cover requests. Mail covers may be issued by the designated approving authority in increments of 30 days; not to exceed 120 days total.

c. MPA Postal Officer/MPO Supervisors will limit mail cover information to those employees and agencies with a “need-to-know” to maintain and protect the privacy of those involved, and the integrity of the mail cover investigation process.

d. MPAs will coordinate with the SCC and provide copies of approved mail cover requests and support documentation. This includes:

- (1) Initial mail cover request (signed copy), and extension requests.
- (2) Postal Matter Information Collection Sheet(s). (See APPENDIX 6B: Postal Matter Information Collection Sheet)

(3) Memorandums for records.

(4) Miscellaneous information relevant to circumstance.

e. MPAs will maintain and perform disposition of mail cover records IAW with the appropriate USPS, DoD or SCC disposition instructions, as applicable.

f. Follow up actions and/or updates are required on “Active” mail covers every 30-days until expired; not to exceed 120 days total.

g. Reproduction, release, and/or sharing of collected postal matter information is not authorized; except to individuals/agencies with an authorized need-to-know.

APPENDIX 6A: MILITARY POSTAL SERVICE MAIL COVER REQUEST

(USE APPROPRIATE COMMAND LETTERHEAD)

[DATE]

(Official Title of Approving Authority)
(Organization/Installation Title)
(Official Address)
(City, State, ZIP Code)

ATTN: (Rank/Name of Approving Authority)

RESTRICTED INFORMATION

1. (*Justification*) This is a request for a mail cover to assist in the identification of property, proceeds, or assets forfeitable under law. Our investigation has developed evidence that the subject J. Doe, 123 Main Street, San Francisco, CA 12345-6789 is engaged in (suspected fraudulent activity).

2. (*Subject*) The cover subject is:

J. DOE (AND ALL OTHER NAMES)
123 MAIN STREET
SAN FRANCISCO CA 12345-6789

NOTE: For the purposes of this mail cover, all mail delivered to this address shall be considered suspect, and subject to review.

3. (*Mail Class*) The mail cover should include information from all mail and correspondence.

4. (*Time Frame*) Mail cover is requested for 30 days, to begin as soon as possible.

5. (*Violation*) Our investigation has disclosed evidence that J. Doe is engaged in (suspected fraudulent activity) in violation of (U.S. Title, Code, Law, or Regulation), and this cover will help identify proceeds and other assets which are subject to forfeiture under (US Title, Code, Law, or Regulation).

6. (*Attorney*) We are unaware of any legal representation for J. Doe. However, if this information becomes available, the name of his attorney will be relayed to you at once.

7. (*Documentation*) Refer to DoDI 4525.09, Section 3.9. and the Military Postal Service Procedures Manual (MPM), Section 6.0,(Mail Covers) , for information and documentation handling and management procedures. We will not reproduce, release, or share collected mail matter data; except to those with an authorized need-to-know.

8. (*Special Instructions*) Postal representative J. Smith, Postmaster, has been contacted regarding this case. (Provide complete name, address, and phone number for case agent, if different than requestor).

(Signature)
(Name of Requester)
(Duty Title, i.e., Special Agent, SJA, etc.)

1st Indorsement;
APPROVED/DISAPPROVED

(Signature)
(Name of Approving Authority / O-6 or above)

APPENDIX 6B: POSTAL MATTER INFORMATION COLLECTION SHEET

RESTRICTED INFORMATION

The Military Postal Service Information Concerning Postal Matter		FILE NO. <i>(optional)</i>	FILE DATE
TO <i>(Name of Postal Inspector)</i>		FROM <i>(Military Postal Activity)</i>	
ADDRESS <i>(City, State and ZIP Code)</i>		DATE	
		POSTMASTER DISCLAIMER: No mail was delayed while obtaining this information.	

INFORMATION IS FURNISHED IN COMPLIANCE WITH APPROVED REQUEST

ADDRESSEE	SENDER	RETURN ADDRESS	PLACE AND DATE OF POSTMARK	METER NUMBER	CLASS OF MAIL (or IDS)

MAIL THIS FORM IN TWO OPAQUE ENVELOPES. DO NOT USE WINDOW ENVELOPES.
 THE INNER ENVELOPE MUST BE MARKED.

"RESTRICTED INFORMATION"

SECTION 7: SEARCHES, INSPECTIONS, SEIZURES AND FRUSTRATED POSTAL

7.1. General.

a. The USPIS is the proponent for privacy and security of postal items. Items are legally protected from acceptance through delivery from search, seizure, inspection and opening under the 4th Amendment to the U.S. Constitution, U.S. law, and USPS/DoD regulations. Mail for OCONUS locations is considered delivered upon delivery to the addressee or agent. DoD Business/Official Mail for CONUS locations is considered delivered upon receipt from USPS; personal mail is considered delivered upon delivery to the addressee or designated agent.

b. IAW the 18 U.S.C. 1702, first class mail in the MPS is protected. The international nature of the MPS allows limited searches, inspections, and seizures to comply with national/international customs requirements.

c. For MPS purposes postal items are sealed against inspection and may not be opened without a search authorization or warrant issued by a military magistrate or a federal court. Search authorization or warrants issued by a state court are not valid for postal items and cannot be used for opening postal items. USPIS may grant specific written authority to open an item on a case-by-case basis.

d. The USPS acceptance process does not hinder or otherwise detect restricted or non-mailable items. The USPS does not assist in complying with host nation requirements for importation.

e. IAW DoDI 4525.09, Section 3.9.j.(1), searches are permitted using visual exterior screening, x-raying, use of military working dogs, and Chemical, Biological, Radiological, Nuclear and Explosive (CBRNE) sensors. A search is the visual screening (including the customs form) of the outside of a container or an item in the postal stream; or use of other electronic devices to comply with host nation customs and import rules or installation security. A search may evolve into seizure (remove from postal stream) or opening of an item (inspection) after judicial approval via a search authorization or warrant.

f. U.S. postal inspectors and customs officials are authorized to enter postal facilities and search receptacles, containers, and postal items.

g. Foreign customs officials may search and seize postal items in the MPS without a search authorization or warrant. MPS personnel will attempt to get a receipt for items seized by foreign customs officials and at a minimum ensure any accountable mail is annotated as being "seized."

h. MPA supervisors may detain a postal item as determined by the search in Section 7.1.e. of this manual, or if it meets the criteria as a suspicious item per USPS poster 84.

i. Items other than CBRNE may not be removed from the postal item, even if not mailable. The emergency opening procedure may not be used to circumvent the search warrant process.

7.2. Requirement.

a. Postal personnel will screen postal items based on the local risk assessment, host nation requirements, US law, and applicable USPS regulations.

b. Postal personnel will contact local emergency responders if postal items meet the suspicious item criteria indicated on USPS Poster 84. This process will not be used to circumvent the requirements for inspecting (opening) a postal item listed in 7.2.g. – 7.2.p. Illegally opening an item will result in prosecution.

c. For items suspected of containing chemical, biological, radiation, or explosive hazards do the following:

(1) Do not move the article and note location for emergency responders.

(2) Secure and evacuate the immediate area.

(3) For explosive hazards, if possible, open nearby windows to vent potentially explosive gases. For chemical, biological, and radiation hazards, isolate exposed personnel and keep upwind from the potentially contaminated site. Shutdown HVAC system to preclude air circulation from spreading contamination.

(4) Account for personnel, keep segregated and retain in the area should first responders need to do preventive medical treatment.

(5) Follow first responder's directions and provide only known facts.

(6) Submit a detailed postal report in AMPS within 24 hours and any follow up reports until situation is resolved and normal operations resume.

d. Emergency responders may open suspicious items as identified by USPS Poster 84. However, if no hazard is discovered all contents even non-mailables must be placed back into the postal item, with MPA memo notification of action, and returned to the postal network.

e. Seize suspicious items meeting criteria illustrated on USPS Poster 84 no more than 72 hours.

(1) Coordinate with emergency services or explosive ordinance personnel to handle items, to include opening. If EOD determines items are explosives or weaponized, EOD shall seize and dispose of items.

(2) MPAs will assist USPIS and other investigative agencies.

f. First responders will destroy explosives and postal items that cannot be decontaminated. MPAs will prepare a memorandum for record if first responders destroy postal items.

g. Postal items cannot be opened without a military or federal search authorization or warrant. During a search if postal personnel see indications that a postal item may contain prohibited contents, contact the nearest military police investigator to draft the affidavit request for a search authorization or warrant. Postal personnel will submit the affidavit request to the military magistrate or federal court. Items removed (seized) from the postal stream awaiting a judicial decision will be secured and not be unduly delayed.

h. The military magistrate or federal court determines if the affidavit meets the probable cause threshold and will grant or deny the request for opening of the article. The request shall not be more than 72 hours to prevent mail delay.

i. Once a search authorization or warrant is granted, the item may be inspected (opened) to view the contents. If the item contains contraband as identified in the search authorization or warrant, it will be seized by law enforcement authorities or investigative agencies. The addressee's commander or civilian supervisor will be notified for appropriate action to be taken which can be restriction to letter class for authorized patrons. Support can be terminated for conditional patrons.

j. Postal personnel will submit an initial postal report upon seizure and follow-up report after search authorization or warrant is executed and contents disclosed. The MPA will maintain a local data file on postal offenses to track trends on contraband items in the mail and any repeat offenders. The MPA will also contact USPIS which can visit the sender of the offending article to discuss the issue.

k. The MPA will conduct PTR scan Event Code \$11 (Seized by Law Enforcement) prior to permitting removal of the postal item from the postal facility. Event code \$11 is visible only to those with a need to know in AMPS to protect investigative information sensitive in nature. The official executing the search authorization or warrant must leave a copy of the search authorization or warrant and a receipt for the postal item seized.

l. Postal personnel will verify the receipt or inventory describes each postal item removed including extra-services endorsements. The receipt or inventory may be attached to the copy of the search authorization or warrant.

m. Until an investigation is completed neither the sender nor addressee will be notified of postal items seized, regardless of extra-services purchased.

n. Process frustrated postal identified by third party screening e.g., airlines, foreign screening service within 48 hours. The identified military postal item may be removed from the mail sack and follow the procedures for international civil frustrated mail. Frustrated military mail handling is a separate process from the search, seizure, and inspection (opening) process in previous paragraphs of 7.2. that required a search authorization or warrant meeting probable cause requirements.

o. Process international civil frustrated mail upon notification from (third party screening e.g. airlines, foreign screening service) reporting authority or DoD personnel (if applicable) by

emailing USPIS Dangerous Goods at dangerousgoods1@usps.gov. In the case where the suspected non-mailable item is discovered within a sealed mail sack and the suspect postal item is not visible for inspection, the reporting authority shall include a photographic image of the associated CN 35 label in its initial report to the USPS. Additionally, adhere to the below recovery measure:

(1) USPIS will attempt to resolve the disposition of the package by contacting the mailer. If the mailer consents to the opening and removal of non-mailable items in the parcel, the USPIS will direct the reporting authority or DoD personnel to open an item and remove the suspected non-mailable content.

(2) USPS shall issue a letter to the reporting authority or DoD personnel providing procedures for handling the suspect parcel and the accompanying parcels in the sack. The letter will authorize the reporting authority to permit DoD personnel to open the mail sack and remove the suspect mail piece.

(3) After opening a suspected postal item and an illegal (under US or host country law) item is identified, the DoD personnel and/or reporting authority shall contact the USPIS and/or the appropriate law enforcement agency to determine proper disposition.

p. Submit list of postal items confiscated by customs and law enforcement officials in AMPS within one workday of seizure.

q. If items are seized or disposed of from the postal stream, submit claims in AMPS and retain supporting documents IAW DoD and USPS records management policy.

SECTION 8: PHYSICAL SECURITY

8.1. General.

a. Security of the mail and protection of postal property and effects is a shared responsibility of the Installation Commander, the Commander responsible for postal, and all personnel performing duties within the MPS.

b. For security of postal items in transit refer to Section 23 Registered Mail and Section 28 Dispatch this manual.

c. Storage and transportation security requirements for OM that may contain classified materials are contained in DoDM 5200.01 Vol 3.

d. USPS facility standards are used for all other storage security requirements.

e. Force protection levels may mandate the search of mail using CBRNE sensors, and x-ray equipment which shall be coordinated with the Physical Security Office (PSO) on the installation.

f. MPAs shall coordinate with the PSO to determine measures required to mitigate potential risk to the installation IAW DoDI O-2000.16. (DoD Anti-terrorism Standards) and DoDI 3020.52 (Installation Chemical, Biological, Radiological, Nuclear and High-Yield Explosives Emergency Response Guidelines).

g. MPAs shall coordinate emergency response and destruction plans with security forces/ first responders to validate the procedures.

h. MPAs will be designated and identified with signage as controlled areas. Non-postal operations and activities will not be co-located within the secure postal processing area of an MPA facility. Non-postal personnel will not have unescorted access to an MPA facility. Contact the supporting PSO for guidance and direction. MPAs will not be used as a shelter in place facility for the base population.

8.2. Requirement.

a. Postal items will be secured at all times IAW USPS and DoD regulations.

b. Overseas postal facilities will have an alarm system, or 24-hour guard and a General Services Administration (GSA) approved safe, vault or a wire mesh cage for storage of official registered mail. Domestic OM and small parcels may contain classified materials and requires a GSA approved safe or vault.

c. Provide locks on doors with hinges meeting the DoD Lock Program and DoDM 5200.01, Vol. 3 requirements. Glass doors used for post office finance lobby entrances will have steel bar or gates for added security.

d. Use SF Form 702, to document each opening and closing of safes and lockable containers. Maintain an Optional Form (OP) 89, inside all safes and take appropriate steps for any repairs/replacements. Post a completed SF Form 700, inside each security container. Post SF Form 701, near the MPA exit for an additional security measure. List containers the MPA uses for the storage of postal funds and stock on the form.

e. Exterior entrances of postal facilities will be illuminated with lights covered with wire screen or other materials to prevent breakage.

f. MPAs will appoint a key control custodian to maintain a master key log and safeguard all keys assigned. The key log must reflect the numbers of keys available and issued for the entire postal operation. NOTE: Issue individual keys using PS Form 1628, Individual Key Record.

(1) Place duplicate keys, or copies of combinations of containers and safes used to store stocks or funds overnight, in PS Form 3977, "Duplicate Key Inventory (Envelope)." Handle sealed envelopes per USPS Handbook F-101, section 3-8.2 Securing Duplicate Keys, Passwords, and Combinations.

(2) Check envelopes during audits of the COPE and during MPO inspections for evidence of tampering. Only the person whose name appears on the front of the envelope may receipt for the envelope.

(3) Duplicate Key Inventory Envelopes will be opened in the presence of a witness. In emergency situations where the issuer or recipient of the envelope are unavailable (i.e., unauthorized absence, hospitalized), the COPE/SC, or Postal Officer/MPO Supervisor will witness opening of the envelope. Under no circumstances will the witness, and issuer or recipient be the same individual.

g. MPAs request annually, in writing, to the responsible agency a physical security inspection of facilities and operations.

h. Display USPS Poster 84 in mail processing areas.

i. Threat prevention measures, and response procedures shall be included in all MPA SOPs.

j. Postal personnel will visually screen all mail.

k. Immediately following a natural disaster or man-made catastrophic event, the MPA supervisor inventories accountable mail and assesses loss or damage to mail and postal effects. If a loss is discovered, the responsible commander appoints an investigating officer to determine reconciliation.

l. The MPA's evacuation plan must include procedures to perform emergency destruction of mail and postal effects. In certain circumstances, postal facilities may request authority (via the SCC) for emergency destruction of mail and postal effects when a threat exists and requires

permanent or temporary relocation of the facility. When authorized, the MPA leaders must carry out the destruction using the following priority (order of precedence):

- (1) Official registered mail.
- (2) Directory service information.
- (3) Blank postal MO forms.
- (4) Currency and coins.
- (5) Postage stamps and stamped paper.
- (6) Paid MOs and checks on hand.
- (7) Retail equipment.
- (8) Other accountable mail.
- (9) All remaining mail.
- (10) All-purpose date and canceling stamps.
- (11) All other records, equipment, mail sacks, and furniture.

(12) When possible, the personnel conducting emergency destruction should ensure there is a witness and submit a list of items destroyed to the SCC.

m. Report postal security violations as a postal report.

SECTION 9: WITHDRAW OR LIMIT MPS PRIVILEGES

9.1. General.

a. Misuse and abuse of the MPS and postal privileges that violate U.S. Title, U.S. Code, laws, or USPS and DoD regulations place privileges of authorized members in jeopardy, as well as negatively impact resources, operational capabilities, and place the entire MPS at risk when HNAs, SOFAs, and other agreements are violated.

b. Service members who misuse, abuse or violate postal policy and procedures may be subject to Chapter 47 of Title 10, U.S.C., also known and referred to in this issuance as the “Uniform Code of Military Justice (UCMJ),” and appropriate civil prosecution procedures for civilian employees.

c. Commanders at all levels shall impose the minimum mandatory penalties listed in this manual but may impose more severe penalties depending on the circumstances. All penalties shall be imposed by an officer having the appropriate UCMJ authority over the offender. DoD civilians and contractors may be prosecuted and removed from the foreign country.

d. Patron authorizations are defined in DoDI 4525.09, as individuals authorized to use MPS within and outside the United States, consistent with international agreements; laws; and Federal, USPS, GSA, and DoD regulations.

e. When sponsorship for family members is terminated, postal privileges are also terminated.

f. Restrictions and revocations are for both prograde and retrograde service.

9.2. Requirement.

a. Military Services will develop and maintain procedures to limit or restrict MPS privileges for patron misuse or abuse.

b. Authorized patrons defined in policy shall not have their ability to send or receive personal letter class mail (or correspondence) revoked for any reason. Patrons authorized MPS privileges through an approval process (i.e., ETP, etc.) will lose all mail privileges when revoked.

c. Commanders shall notify the senior manager of the supporting MPA where the offense was committed of actions taken against the offender.

d. In addition to any action that may be taken under the UCMJ or the federal law, the following penalties will be taken for misuse, abuse or misconduct associated with the MPS by non-postal personnel:

- (1) First Offense: Written warning which outlines specific violation, consequences for continued misconduct associated with the MPS, and patron’s written acknowledgement (signature) of understanding.

(2) Subsequent Offenses: Document circumstances of reoccurrence, forward case file to member's respective commanders for administrative action.

e. A 90-day notice of withdrawal or limitation of service will normally be given to authorized patrons but is not required for MPS abuse, conditions beyond the control of the DoD, or if mandated by the host government.

f. Copies of warnings or other penalties under this enclosure shall be maintained at the local post office for 36 months from offense and scanned into the respective Postal Report in AMPS.

g. Commanders will ensure full coordination with affected organizations and individuals, postal command channels, and the MPSA prior to implementing limitations or withdrawal of a patron's privileges.

h. The postal manager shall notify MPSA of all actions taken under established policy through AMPS Postal Report. Required notification actions include:

(1) Initial Postal Report via AMPS of postal violation.

(2) Follow-up reporting every 30-days via AMPS until Postal Report is closed.

(3) Prior to closing report in AMPS, the Postal Report will include final result/resolution. Postal managers will ensure all support documentation are uploaded into the respective Postal Report in AMPS.

SECTION 10: SUPPORT FOR COALITION FORCES AND UNITED NATIONS

10.1. General.

a. Unless otherwise provided for in an international agreement, foreign military units serving with the U.S. Armed Forces may receive reimbursable mail support. CCDR's should use an implementing arrangement to an existing Acquisition and Cross Servicing Agreement (ACSA) IAW DoDD 2010.9 to authorize postal support, detail processes, and identify reimbursement arrangements for requesting coalition forces to receive MPS support. Mail for Coalition Forces is subject to the same restrictions as those applied to U.S. Forces, though additional individual country restrictions may apply.

b. Foreign forces requesting mail support must provide request to CCDR of the AO.

c. The UN is recognized as a formal postal administration. USPS honors the UN frank and stamps.

d. The UN may provide official and personal mail service for contingent military personnel from the UN mission area to home countries (retrograde service only) and must be franked with the UN impression. This service does not apply to prograde service (from home countries to contingents).

e. For UN, only first-class letters, and post cards, weighing 10 grams or 1/3 of an ounce or less will be accepted as mail from members of the contingent. Individuals are entitled to dispatch up to five letters per week, including UN aerogrammes. No enclosures are permitted in aerogrammes. CCDRs may provide support to UN forces for LCM.

f. Postal support for US forces deployed under the UN is a US responsibility.

10.2. Requirement.

a. Coalition forces should use the coalition country's military postal system, international mail, direct air freight, commercial airlines, or the coalition country's diplomatic pouch systems instead of the MPS.

b. CCDR completes an implementing arrangement document as an official request with POC information. An example of the ACSA and template of ACSA is available in AMPS in Knowledge Management tab.

c. When drafted, CCDR coordinates the implementing arrangement with MPSA.

d. MPSA coordinates with USPS and requesting CCDR on approval to proceed.

e. CCDR obtains the requesting coalition country's ministry of defense signature and the CCDR'S J-4 signature on the implementing arrangement.

f. When implemented through the CCDR country team, the mail and reimbursement process includes the following steps:

(1) The receiving MPO completes the implementing arrangement form for reimbursement and submits to the CCDR postal manager along with a copy of the billing document. The reimbursement form requires signatures from both parties.

(2) Prograde postal is routed to the destination MPO for transfer to the coalition military unit. Retrograde postal is routed to the coalition country for transfer to the coalition country's postal service.

(3) The Military Services submit reimbursement forms electronically to Defense Finance and Accounting Services (DFAS) through the CCDR ACSA representative and J8 to start the reimbursement process.

(4) If the coalition country requesting postal support is located in the operational area of another CCDR, coordination must be made between the postal staff of both CCDRs.

(5) DFAS bills the coalition government using established processes, receives the payment, and transfers the payment to the entity submitting the reimbursement document using the fund cite annotated on the reimbursement form.

g. CCDR's may use an MOU/MOA only when an ACSA does not exist. Procedures for requesting MPS support for coalition/UN forces using an MOU or MOA are:

(1) The CCDR's staff evaluates the request and submits to MPSA for OSD approval.

(2) MPSA coordinates implementation with applicable agencies (e.g., USPS, Customs, DFAS etc.) and notifies the CCDR's postal staff upon completion.

(3) The CCDR's postal staff verifies that the coalition country agrees to pay mail transportation costs. Billing procedures are established in the MOA prior to implementation.

(4) If the coalition country requesting postal support is located in the operational area of another CCDR, coordination must be made between the postal staff of both CCDRs.

(5) Upon approval of the coalition country postal support request, the CCDR's postal staff coordinates start dates with MPSA. The MPSA verifies MOA billing procedures with DFAS and secures USD(A&S) approval.

SECTION 11: ENEMY PRISONERS OF WAR/DETAINED PERSONNEL/ INTERNEES (EPW/DP/I)

11.1. General.

a. Correspondence addressed to or dispatched by Enemy Prisoners of War/Detained Personnel/Internees (EPW/DP/I) may be censored pursuant to Art. 76 of the Third Geneva Convention (Prisoners of War) and Art. 112 of the Fourth Geneva Convention (Civilians). The theater commander may institute censorship of EPW/DP/I incoming and outgoing mail in accordance with the procedures set forth in AR 190-8/OPNAVINST 3461.6/AFJI 31-304/MCO 3461.1.

b. The International Committee of the Red Cross negotiates details for handling EPW/DP/I mail with the DoS as the US representative. This support is non-reimbursable.

c. Under USPS and Geneva Convention guidelines, the Provost Marshal manages postal support for EPW/DP/I; to include determining size, weight, and quantities of letters, cards and parcels.

11.2. Requirement.

a. Postal personnel transfer prograde closed bags to the Provost Marshal and receive and coordinate retrograde postal transportation.

b. Receptacles containing prisoner of war mail must be sealed and labelled to clearly indicate the receptacle contents and must be addressed to offices of destination.

c. Notify the MPSA of EPW/DP/I support.

SECTION 12: POSTAL PERSONNEL

12.1. General.

- a. Title 39, U.S.C., USPS Pub 38 and DoDI 4525.09, Section 3 require appointment of postal personnel.
- b. Personnel of questionable character will not be assigned to duties in MPAs. Personnel must be honest, trustworthy, and physically capable of performing postal duties.
- c. Designated personnel must be informed of their responsibilities, obligations, and liabilities in handling postal funds and mail.

12.2. Requirement.

- a. Postal personnel will be appointed in writing by Commanders or designated representative. MPA duties should be assigned to individuals who possess a high moral standard, and have no record of:
 - (1) Conviction of a crime involving theft or moral turpitude.
 - (2) Disciplinary actions reflecting unfavorably upon their truthfulness or integrity, in the past five years.
 - (3) History of psychiatric disorder, alcoholism, or drug misuse (medical conditions), without complying with the requirement of the Rehabilitation Act (individualized assessment, interactive processes, reasonable accommodation, etc.).
- b. They must be financially responsible.
- c. They must not have been relieved from postal duties for cause.
- d. Personnel will have a favorable background check prior to appointment as part of the hiring process.
- e. Personnel having access to the registered mail cage, supervising official mail operations or designated to open official registered mail overseas, and official mail and small parcels in the United States must have an adjudicated "SECRET clearance." Personnel transporting items that could contain classified materials must be US citizens.
- f. Personnel must not have a permanent physical restriction prohibiting duty involving prolonged standing, walking, or lifting of weights up to 70 pounds; or place either themselves or co-workers at risk of injury.
- g. Members of the MPS, assigned to and responsible for performing MPA duties, will be appointed on a Designation Letter signed by the responsible postal commander/authority. In

addition to the required Designation Letter of appointment, use of the DD Form 285 and/or 2257 is at the discretion of the Military Service Component. Additional appointment instructions:

(1) Designation Letter of Appointment must indicate: (refer to template located in AMPS, Knowledge Management)

(a) Appointees Title (i.e., Military Postal Clerk, or (civ) Postal Clerk).

(b) Key position within the MPA, if applicable (i.e., PFO, COPE/SC, OPM, Registry Clerk, Supply Custodian, etc.).

(c) Category of postal items authorized to handle. (i.e., All, Personal, Official, Official (except Registered), Personal (except Accountable)).

(d) Security Clearance and Date (if applicable)

(2) For Local National MPA employees, list "Except Official Regs" for mail authorized to handle.

(3) List "Augmentee" for Title of Appointee for non-postal personnel detailed to support the MPA (where and when applicable).

(4) In addition to a Designation Letter of Appointment, MPA personnel and MPA augmentees must sign a PS Form 8139

(5) Volunteers must only sign a PS Form 8139. Postmasters will ensure volunteers are briefed on the importance of mail security, the privileged nature of mail, and work center safety

h. MPAs maintain Designation Letters of Appointment for Postal Personnel as follows:

(1) File one at MPA and provide one to the individual.

(2) File the PS Form 8139 in the MPA.

i. Unit, organization, or agency personnel, assigned to and responsible for performing unit mail handling duties, will be appointed on a Designation Letter signed by the responsible commander. In addition to the required Designation Letter of appointment, use of the DD Form 285 and/or 2260 is at the discretion of the Military Service Component.

(1) Designation Letter of appointment must indicate: (refer to template located in AMPS, Knowledge Management)

(a) Appointees Title; Unit Postal Officer, Unit Postal Clerk, Postal Orderly.

(b) Category of postal items authorized to handle. (i.e., All, Personal, Official, Official (except Registered), Personal (except Accountable)).

(c) Security Clearance and Date (if applicable)

(2) For Local National, UPR employees, ensure Designation Letter list “Except Official Regs” for mail authorized to handle.

j. Units/organizations will maintain a copy of the Designation Letter of Appointment documentation for unit personnel, provide and maintain a current copy at the MPA, and provide one to the individual(s).

k. Temporarily-hire and Augmentee personnel will work under the direct supervision of trained postal personnel at all times; to include after having been trained to established standards, and properly appointed as required.

l. Augmentee personnel will not be issued financial accounts or permitted to handle funds.

m. Postal personnel who engage in misconduct, are suspected of theft, or posing a threat to the MPS or personnel will be removed from the MPA. Postal personal should be temporarily assigned non-MPA duties pending the outcome of an investigation of suspected misconduct.

n. Personnel relieved from postal duties or ending postal handling responsibilities at a specific duty location will be terminated on their respective Designation Letter of Appointment.

SECTION 13: TRAINING

13.1. General.

a. USPS Pub 38 and DoDI 4525.09, Section 3.2. require training of postal personnel. Training is divided into three categories: Formal, Informal, and Continuum (postal) training.

b. Formal training is the preferred method when assigned to the following positions: Postmaster, PFO, COPE/SC and PC.

c. The DoD shall train DoD postal personnel, appoint them in writing, and assign only qualified postal personnel to positions in the MPS. All assigned personnel must meet minimum current Federal Investigative Standards for personnel security. A person disciplined for an action reflecting unfavorably upon their integrity will not perform postal duties.

d. Inter-service Postal Training Activity (IPTA), Mobile Training Team (MTT) support will be funded by requesting organization.

e. Advanced supervisory certification workshops and training opportunities include; Certified Direct Mail Professional, Executive Mail Center Manager, US Postal Service Professional Training are available through coordinated requests.

13.2. Requirement. Qualified postal personnel are uniformed service members who have received formal postal training at the DoD accredited postal school or a DoD civilian employee who has received informal training from qualified postal personnel within six (6) months of employment. The DoD accredited postal school is the Interservice Postal Training Activity (IPTA).

a. Formal Training. Attend and pass training listed in Appendix 13A as appropriate for supervisors and clerks at the IPTA, or by an associated MTT. This includes virtual or visual media instruction (provided by the IPTA, or associated MTT). Formal training is required for uniformed service members prior to initial assignment as a postal clerk or a postal supervisor.

b. Informal Training. Distant Learning (DL) or On-the-Job-Training (OJT) may suffice for up to one year from assignment. DL is computer based or correspondence. OJT is conducted under the supervision of a formally trained person.

c. Continuum Training. Addresses development at all levels of an organization, with relative targeted training. It also serves as refresher training for personnel who have not served in a postal position for an extended period of time. DoD components shall ensure postal employees continuously receive the following training to develop and maintain proficiency:

- (1) Policy and procedure updates.
- (2) Mail security, privacy, and dangerous goods.

(3) Retail operations, i.e., acceptance, audits, reporting.

(4) OPM Training, i.e., Private Express Statute (PES), classified materials, weapons, annual report, shipping options.

(5) Transportation and mail handling, i.e., accountable mail.

(6) Absentee Ballot Voting acceptance and processing procedures.

d. Postal personnel must receive training commensurate with the assigned positions, (i.e., PFO, COPE/SC, supply custodian, registry clerk, directory clerk, etc.).

e. MPA training programs should include initial and reoccurring training associated with professionalism in the workplace commensurate with the following core elements:

(1) Productivity - Use time constructively while on on-duty and focus on job responsibilities. Limit personal use of social media, web browsing and phone activity while on duty.

(2) Dress and appearance – Project a professional presence and dress appropriately. Employee attire should be appropriate, in good-taste, clean, dry and serviceable.

(3) Maintain effective work habits – Prioritize and properly manage duties and responsibilities. Follow up and follow through with your supervisor and team members.

(4) Demonstrate integrity – Be accountable for your work and actions, upfront and honest with your supervisor and team members.

(5) Deliver excellence – Produce results that reflect a sense of pride and professionalism, often exceeding expectations.

(6) Communicate effectively – Practice and hone professional on-line, in person and written communication skills.

(7) Network – Build relationships with colleagues and customers foster professional relationships, promote teamwork and collaborative efforts.

f. MPA training programs should foster and promote initial and reoccurring training associated with quality customer service synonymous with the following fundamental characteristics:

(1) Respect – Treat others as we would like to be treated. Regardless of the situation and the behavior of others, good customer service skills dictate that we be respectful at all times. The following are basic examples of simple ways to show respect:

(a) Use the customer's name.

- (b) Actively listen, do not interrupt the customer.
- (c) Maintain eye contact with the customer while they are speaking.
- (d) Wait until customer has finished before offering a response.

(2) Patience – Customers with questions or problems will want to explain details of the situation. Employees demonstrate good customer service skills by actively listening and letting the customer talk until finished. This helps the customer feel they have been heard and will improve an adversarial situation.

(3) Self-Control – Remain calm, allow the customer to articulate the issue or frustration without creating an antagonistic situation.

(4) Concern – Good customer service includes demonstrating concern for the customer regardless of the situation and reflects on the reputation and credibility of the organization.

(5) Attentiveness – Make eye contact, listening to what the customer has to say, following the conversation, and responding appropriately. Employees should remain focused on the customer—and resolving the issue at hand.

(6) Empathy – The ability to sense and understand the emotions of the customer, then focus on resolving the situation or reach the best outcome.

(7) Flexibility – Remain open-minded, willing to listen, focused on “solving-for-yes” to produce the best results.

(8) Communication Skills – Good communication skills involve active listening, body language, facial expressions, tone of voice, and much more. The following are examples of good communication skills:

- (a) Keep your body relaxed.
- (b) Show concern (face).
- (c) Maintain a calm and neutral tone of voice.
- (d) Use positive language (words like can, will, help, resolve) when responding.

(9) Effective Listening – This enables the employee to correctly interpret what the customer is attempting to communicate. Effective listening involves understanding both what is being said, as well as what is not. Not making the distinction between these two things can cause communication to break down and lead to customer frustration and dissatisfaction.

(10) Responsibility – Reassure the customer the problem or issue is a priority until it is

resolved.

(11) Efficiency – Solving customer complaints may involve numerous steps necessitating efficiency. Address the problem and work a solution as quickly as possible. Quick resolution to a problem, even if it involves multiple steps, can make a customer feel valued and reinforces positive perceptions of the organization.

(12) Positive Attitude – Staying positive can influence all involved to remain calm and take a better view of things which makes finding a solution much easier.

(13) Decisiveness – Encouraging employees to make decisions and supporting those decisions can bring about a quick resolution to most problems. If an employee is presented with a complaint and the solution is obvious and simple, enable the employee to make the decision.

(14) Creativity – No two problems are the same and resolving an issue may require a not so obvious solution. Creative solutions may stick with a customer and reinforce the customer service reputation of the organization. Encourage creative problem solving in the work center.

(15) Assertiveness – Manage the situation and strive to reach a successful conclusion. Assertiveness and decisiveness often go hand in hand.

**APPENDIX 13A: INTER-SERVICE POSTAL TRAINING ACTIVITY (IPTA)
APPROVED PROGRAM OF INSTRUCTION (POI) FOR THE POSTAL
OPERATIONS AND POSTAL SUPERVISOR COURSES.**

13A.1. Reference

a. DoDI 4525.09 section 3.2.c. requires MPS personnel performing postal duties to be qualified and formally trained using a common set of basic criteria as coordinated and approved by MPSA and the Military Services. IPTA curriculum has been reviewed and approved utilizing Interservice Training Review Organization (ITRO) methodologies and guidance to develop postal training that meets the standard established by DoDI 4525.09.

13A.2. Postal Operations Course Purpose

a. To train enlisted personnel in grades E1 thru E9 from all branches of service (Active and Reserve Component), officer personnel 01 thru 04, warrant officer 1 thru 5, and civilian personnel on procedures involved in the operation of an MPO. Provide students training on MPS, AMPS, and designation of military postal service personnel. Approved POI includes the following lessons:

<u>LESSON TITLE</u>		<u>HOURS</u>
1.	Maintain Stamp Stock	16
2.	Conduct Money Order Business	8
3.	Process Domestic Mail	8.5
4.	Process Domestic Mail Requiring Special Services	22
5.	Process International Mail	23
6.	Process Mail	3
7.	Prepare Mail Transportation Documentation	12
8.	Process Registered Mail	16
9.	Operate a PSC	14
10.	Conduct Postal Directory Functions	18
11.	Maintain Postal Supplies	10.5
TOTAL ACADEMIC HOURS		187

13A.3. Postal Supervisor Course Purpose

a. To train commissioned/warrant/noncommissioned officer personnel of the Army, Navy, Air Force, Marine Corps, Coast Guard, and civilian personnel in advanced postal technical skills and management techniques required of first line postal supervisors. This course of instruction provides training on all critical tasks regarding MPS responsibilities, postal financial management, perform supervisory functions on the POS One system, mail security, mail

transportation and postal inspections. The Postal Supervisor Course produces a mid-grade leader, both doctrinally sound and technically capable of delivering Postal support as the COPE, Postal Officer, and Postal Supervisor within a postal organization who are also effective communicators and critical and creative thinkers. Approved POI includes the following lessons:

<u>LESSON TITLE</u>		<u>HOURS</u>
1.	Identify MPS Responsibilities	18
2.	Operate the AMPS Database	13
3.	Conduct COPE Duties	24
4.	Perform Point of Service (POS) ONE Supervisor Functions	24
5.	Inspect a MPO	24
TOTAL ACADEMIC HOURS		103

13A.4. Postal Operations Course Lesson Summary and Performance Standards

a. Lesson Title: Maintain Stamp Stock

(1) Standard: Maintain the stamp stock by filling out the correct forms for issuing stamp credit accounts, ordering stamps, documenting daily balance of stamp stock and recording the daily balance of stamp stock on hand IAW MPM. Students will be assessed within 80% accuracy during the following learning activities:

- (a) Designate and terminate Postal Finance Clerk.
- (b) Receipt for a Flexible Credit Stock.
- (c) Conduct an Audit of a Flexible Credit Stock.
- (d) Replenish a Stamp Stock.
- (e) Exchange Damaged Stock.

b. Lesson Title: Conduct Money Order Business

(1) Standard: Students will be assessed with a minimum of 80% accuracy during the following learning activities:

- (a) Control Postal Money Orders.
- (b) Prepare Postal Money Order Form Set.
- (c) Issue Postal Money Orders.

- (d) Administer Cashing Postal Money Orders.
- (e) Produce a Clerk Money Order Tape.

c. Lesson Title: Process Domestic Mail

(1) Standard: Accept and process domestic mail using the correct forms and endorsements, assess the correct amount of postage and fees, determine if mail is mailable and verify the customer's authorization to use the MPO. Students will be assessed with a minimum of 80% accuracy during the following learning activities:

- (a) Employ the Integrated Platform Scale and Postage Meter.
- (b) Process Domestic Mail.
- (c) Identify Postal Publications.
- (d) Identify Wrapping and Packing requirements.
- (e) Determine Maximum Size Limits.
- (f) Process First-Class and Priority Mail.
- (g) Process Media Mail.
- (h) Process Retail Ground Mail and Space Available Mail (SAM).
- (i) Identify Nonmailable matter.
- (j) Process Priority Express Mail.

d. Lesson Title: Process Domestic Mail Requiring Special Services

(1) Standard: Accept and process domestic mail requiring special services by using the correct forms and endorsements, determine the correct amount of postage and fees, if the item is mailable, if special services are available, and verify the customer is authorized to use the MPO. Students will be assessed with a minimum of 80% accuracy for the following learning activities:

- (a) Perform RSS functions.
- (b) Process Insured Mail.
- (c) Process Certified Mail.
- (d) Process Return Receipt Requested.

- (e) Process Certification of Mailing.
- (f) Process Registered Mail.
- (g) Process Restricted Delivery Mail.
- (h) Process Customs Declarations.

e. Lesson Title: Process International Mail.

(1) Standard: Accept and process international mail for authorized customers using the correct forms and endorsements, assessing the correct amount of postage and fees, determining if mail is mailable, and providing special services. Students will be assessed with a minimum of 80% accuracy during the following learning activities:

- (a) Identify the two categories of international mail processed by MPOs.
- (b) Determine conditions for mailing international mail.
- (c) Provide special services for international mail.
- (d) Identify country-specific requirements for international mail using the Individual Country Listings (ICL).

f. Lesson Title: Process Mail

(1) Standard: Receive, process, collect, deliver, and dispatch mail in accordance with MPM. Students will be assessed with a minimum of 80% accuracy during the following learning activities:

- (a) Receive dispatched mail.
- (b) Prepare mail for delivery.
- (c) Process accountable mail.
- (d) Collect mail for dispatch.
- (e) Prepare mail for dispatch.
- (f) Dispatch mail.
- (g) Perform receptacle dispatching procedures (nesting).

g. Lesson Title: Prepare Mail Transportation Documentation

(1) Standard: Document mail shipments properly by obtaining a receipt for mail that is dispatched, report irregular handling of military mail, and complete PS Form 2942-A, DD Form 1384, DD Form 1372, and PS Form 2759. Students will be assessed with a minimum of 80% accuracy for the following learning activities:

- (a) Identify mail transportation requirements.
- (b) Prepare Military Mail AV-7 Delivery List (PS Form 2942-A).
- (c) Prepare a Mail Manifest (DD Form 1372).
- (d) Prepare Transportation Control and Movement Documentation (TCMD) (DD Form 1384 and PS Form 2942-A).
- (e) Prepare a Report of Irregular Handling of Mail (PS Form 2759).

h. Lesson Title: Process Registered Mail

(1) Standard: Process registered mail by verifying all registered mail in pouches and sacks, opening all mail in the presence of a witness, taking appropriate action if any discrepancies are found, completing the correct forms, deliver and dispatch registered mail, secure the registry section and all registered mail and provide postal security. Students will be assessed with a minimum of 80% accuracy during the following learning activities:

- (a) Definition of Terms
- (b) Process Incoming Registered Mail.
- (c) Receive Registered Mail from other sources.
- (d) Deliver Registered Mail.
- (e) Dispatch Outgoing Registered Mail.
- (f) Close a Registry Section.

i. Lesson Title: Operate a PSC

(1) Standard: Provide PSC service to eligible customers by issuing mail receptacles, closing mail receptacles, and delivering mail that is too large for the receptacles. Students will be assessed with a minimum of 80% accuracy during the following learning activities:

- (a) Communicate postal services provided by a PSC.
- (b) Manage mail receptacles.

- (c) Perform PSC mail processing functions.
- (d) Close mail receptacles for out-processing personnel.

j. Lesson Title: Conduct Postal Directory Functions

(1) Standard: Conduct postal directory functions by processing directory mail received from the unit mail clerks and other sources, maintaining the directory file on all persons served by the military, endorsing mail accordingly, dispatching mail if necessary, and putting directory service stamp on back of mail. Student will be assessed with a minimum of 80% accuracy during the following learning activities:

- (a) Maintain Directory Files.
- (b) Process Directory Mail.
- (c) Process Undeliverable as Addressed Mail.
- (d) Process Hold Mail, Refused Mail, Incorrectly Addressed/ Illegible Mail, Casualty Mail, and Dead Mail.

k. Lesson Title: Maintain Postal Supplies

(1) Standard: Inventory postal supplies and ensure items are ordered, issued, and received. Students will be assessed with a minimum of 80% accuracy during the following learning activities:

- (a) Control procurement of USPS supply items.
- (b) Store supplies and monitor inventory control.
- (c) Issue and requisition USPS supply items.
- (d) Receive USPS postal supplies.

13A.5. Postal Supervisor Course Lesson Summary and Performance Standards

a. Lesson Title: Identify MPS Responsibilities

(1) Standard: Students will be assessed with a minimum of 80% accuracy during the following learning activities:

- (a) Summarize the history, legal mandates, and primary functions of the MPS.
- (b) Identify who can use the MPS.

- (c) Report abuse/misuse of MPS.
- (d) Identify channels of communication.
- (e) Identify MPS chain of command.
- (f) Identify responsibilities of the JMPA in postal matters.
- (g) Identify postal activity security and safety responsibilities.
- (h) Identify and initiate care and protection of stock funds and money orders.

b. Lesson Title: Operate the AMPS Database

(1) Standard: Students will meet the minimum standard of 80% accuracy when they complete the following learning activities:

- (a) Navigate the AMPS.
- (b) Prepare PS Form 2942-A, Military AV-7.
- (c) Prepare PS Form 2734-B, Air Transportation Pay and Routing Adjustment.
- (d) Prepare PS Form 2759, Report of Irregular Handling of Military Mail.
- (e) Prepare and Submit PNAs.

c. Lesson Title: Conduct COPE Duties

(1) Standard: Students must meet the minimum standard of 80% accuracy for the following learning activities:

- (a) Designate and terminate the COPE.
- (b) Conduct audit of money order accounts.
- (c) Verify dollar value of a flexible credit account.
- (d) Conduct inventory of accountable postal equipment.
- (e) Perform Eagle Cash (EC) postal functions.

d. Lesson Title: Perform POS ONE Supervisor Functions

(1) Standard: Students will be assessed within 80% accuracy during the following learning activities:

- (a) Apply POS ONE Components
- (b) Apply eAccess
- (c) Apply POS ONE User Roles
- (d) Apply Back office User Roles

e. Lesson Title: Inspect a MPO

(1) Standard: Inspect a MPO accurately documenting all deficiencies identified on the MPS Inspection Checklist and providing the corrective action for all deficiencies marked as "Improve or No". Students will be assessed with a minimum of 80% accuracy during the following learning activities:

- (a) Inspect Military Postal Finance Section.
- (b) Inspect Military Postal Operations Section.
- (c) Inspect Military Postal Services Section.

SECTION 14: ADDRESS MANAGEMENT

14.1. General.

- a. USPS Pub 28 and DoDI 4525.09, Section 3.10. outline requirements for addresses.
- b. Local city planning or zoning offices and USPS Address Managers are responsible for assigning city-style street addresses on DoD installations in the U.S. Written requests for adding streets and any secondary unit designators must be sent to the Address Management System (AMS) Office responsible for the area where the street addresses are located.
- c. MPAs can view the address standard format at <https://www.usps.com>, click Quick Tools, and "Look Up a ZIP Code." If the address cannot be verified, contact MPSA.

14.2. Requirement.

- a. Military Services will submit requests for address creation via AMPS. SCCs will maintain current ZIP Code Plus 4 inventories in AMPS reflecting addresses served and follow standard formatting for unit information. SCCs will not disseminate addresses for use until published in the Postal Bulletin and active in USPS systems.
- b. MPSA will approve or disapprove AMPS requests for address creation, provide reason for disapproval, and ensure unit address information is entered, updated, and deleted in USPS systems.
- c. The acronyms CPR, OPC, PSC, and UPR will be used only in overseas MPO military addresses.
- d. Official Postal Managers (OPM) must coordinate with the servicing MPA or USPS Postmaster for new, relocating, or deactivating organizations.
- e. MPAs must ensure the Address Listing in AMPS is updated with valid address.
- f. Military addresses will be AMS compliant.

SECTION 15: FACILITIES

15.1. General.

- a. Installation Commander / MPS Postal Officer or Supervisor evaluate initial planning and proposed moves of postal facilities to ensure locations meet the structural criteria.
- b. SMEs should develop open floor plan designs to accommodate efficient mail flow and support postal volumes when planning design upgrades or construction of new MPA facilities.
- c. The space criteria for a military postal facility shall be based on the total population serviced by the postal facility.
- d. The USPS publications provide necessary information to define how postal facilities are to be designed and constructed. The USPS publications are to be used on all postal facilities including new construction, repair, or alteration design and construction activities regardless of size.
- e. Limit facility office space to essential postal functions.
- f. Additional space may be needed if an MPO or OPC performs specialized functions, such as high-volume mailers or activities generating a high volume of accountable mail that requires secure overnight storage.

15.2. Requirement.

- a. This manual, USPS handbooks USPS AS 503 (Standard Design Criteria), AS 504 (Space Requirements), AS 506 (Architect and Engineer Project Requirements) and the Administrative Service Manual and other DoD regulations provide guidance on facility construction and design requirements. Exceptions to facility/security requirements must be submitted through local leadership; (i.e., Directorate of Public Works (DPW), Civil Engineer (CE), Security Forces (SFS) to the SCC for staffing to MPSA).
- b. Postal facilities must provide a safe and healthy environment and secure storage for postal effects, and classified material IAW DoD Manual (DoDM) 5200.01 Vol. 3 and DoD 5200.08-R.
- c. Block customer access and visibility to mail processing areas through the use of walls, furniture, counters, half doors, etc.
- d. MPA mail processing operations will be located on the ground floor.
- e. Provide lockable storage outside the mail processing area for employees to store personal belongings. Items which may conceal postal (i.e., backpacks, jackets, bags, etc.) are subject to inspection and not allowed in mail processing areas.
- f. Construction Criteria for an MPO:

- (1) Stand-alone building with isolated airflow system.
- (2) Construct postal retail service counters for use with USPS equipment.
- (3) The retail service area will be constructed to have the ability to be secured after closing hours.
- (4) Truck dock to accommodate commercial trucks with minimum clearance for 40ft container.

g. Space Criteria for an MMT shall be determined based off the population serviced, consider the following:

(1) Direct support. Facility space to accept, collect, cancel, sort, redirect, mass, scan, nest, manifest, dispatch and delivery of unit or personal postal; may include retail services when required.

(2) General support. Facility space to Bulk separate postal for onward dispatch. To include postal from a civilian post office or UPR to other facilities; may include retail services when required.

h. The following are recommended planning considerations within the MPA for mission support:

- (1) Receipt and dispatch section.
- (2) Registered mail section.
- (3) Supply and Equipment section.
- (4) Unit Postal Room delivery section.
- (5) Administrative section.
- (6) Retail section.
- (7) Design the facility so supervisors can see the entire work area.
- (8) Additional considerations:
 - (a) Workflow, mail processing and staging.
 - (b) Mail conveyer systems.
 - (c) Mail screening systems.
 - (d) Mail volume.

- (e) Unique operational requirements such as mailing needs after duty hours.
 - (f) Customs section.
 - (g) Training room.
- (9) Structure:
- (a) Walls and ceilings. Will be constructed to prevent penetration.
 - (b) Doors. MPA access doors shall be constructed IAW AS 503, and the number of facility access doors kept to a minimum.
 - (c) Windows. Equip first floor and ground level windows with a heavy metal frame and vertical dividing bars to prevent the passage of a person's body. Cover windows located at least 10 feet above ground level and second story windows with wire mesh security screening.
 - (d) Registry. "A wire mesh cage is the preferred option for a registry section within a MPA due to the ability to relocate, expand and visibility." A separate enclosed room without a drop ceiling or a wire mesh cage to provide security against unauthorized entry. Use AS 503 guidance referencing the use of wire mesh cage requirements.
 - (e) Intrusion Alarm Devices (IAD). At overseas postal facilities where official registered mail services are provided, continuous monitoring of the facility is required. An IAD (Joint-Service Interior Intrusion Detection Systems (J-SIIDS)) is the preferred means/method of monitoring. If an IAD is not available, a 24-hour guard on the building is required for security of classified materials IAW DODM 5200.1, Vol.3. These requirements will not be waived.
 - (f) Duress alarms, Camera, Surveillance System. MPAs may install systems in the lobbies, registry section, postal processing area, COPE/SC and postal finance sections as listed in the AS 503 to enforce local security requirements.
 - (g) Loading Dock Space. Postal facilities should have sufficient parking, loading and off-loading space. Truck docks should be equipped with a lift and adequate maneuvering space to accommodate various commercial trucks; with minimum capability for 40ft containers. Loading doors and docks should have sufficient roof overhang to load and off load mail without exposing the mail to inclement weather. Add door and docking space to total required space allocation in facility planning.
 - (h) Parking Space. MPAs must have adequate parking space for customer parking and UPRs vehicles.
 - (i) Signs. MPAs will be identified with signage IAW installation regulations. MPAs shall be designated as controlled areas with appropriate signage.

(j) These facility procedures apply to permanent structure land-based facilities. Shipboard post offices, contingency operations, and temporary facilities will conform to floor space, structural, and facility standards to the maximum extent possible. Security of OM which could contain classified must meet the requirements IAW DoDM 5200.01, Vol. 3.

APPENDIX 15A: MILITARY POSTAL ACTIVITY DESIGN

Postal facility construction and design must consider the following criteria (a)

MPS Population	500	2500	5000	10000	20000
Net Square Feet	1693	3613	6013	10813	20413

Delivery receptacle per population (b/c/d)

The selection of box types will follow current USPS standards. Varied box configurations can be used to meet local operational requirements.

Type	Size	Box per Section	Box AVG per SF. (AVE SF)	Purpose
#1 Box - X-Small	H = 5 1/2" W = 3" D = 14 3/4"	60	.56	Smallest box fits 10-15 letter sized envelopes or up to 2 rolled magazines
#2 Box - Small	H = 5 1/2" W = 5" D = 14 3/4"	40	.84	Square option can accommodate 10-15 letters or up to 5 rolled magazines
#3 Box - Medium	H = 5 1/2" W = 11" D = 14 3/4"	20	1.67	Medium size accommodates stacked flat large envelopes and magazines
#4 Box - Large	H = 11" W = 11" D = 14 3/4"	10	3.34	Large size accommodates 2 shoeboxes stacked with room for 10-15 letters
#5 Box - X-Large	H = 12" W = 22 1/2" D = 14 3/4"	5	6.67	Largest option for Flat Rate Boxes, parcels, or incoming shipments

Module Description	Net Area - SF.	Comments
Typical Box Lobby - saw tooth alcove	400	12 Delivery receptacle Sections
Typical Box Lobby - rectangular alcove	800	25 Delivery receptacle Sections

a For population over 20,000 contact SCC for guidance.

b A Delivery receptacle module is 2-Ft wide and may contain the following boxes: 12 number one boxes, 8 number two boxes, 4 number three boxes, 2 number four boxes, or 1 number five box. A section contains five modules stacked vertically and is 2-Ft wide.

c To obtain minimum size of CPR/PSC sq. feet add 25% to total box use and multiply by AVG SF. Example #1 Box: $(576 + 144) \times .55556 = 400$ SF.

d The square footage of box section is in addition to the postal facility design.

e All efforts should be made to account for increased e-commerce parcel volumes during facility planning. Parcel lockers, and "smart lockers," accessible 24/7 are the best-practice solutions to deliver large volumes of parcels to customers.

APPENDIX 15B: MPO LAYOUT EXAMPLE

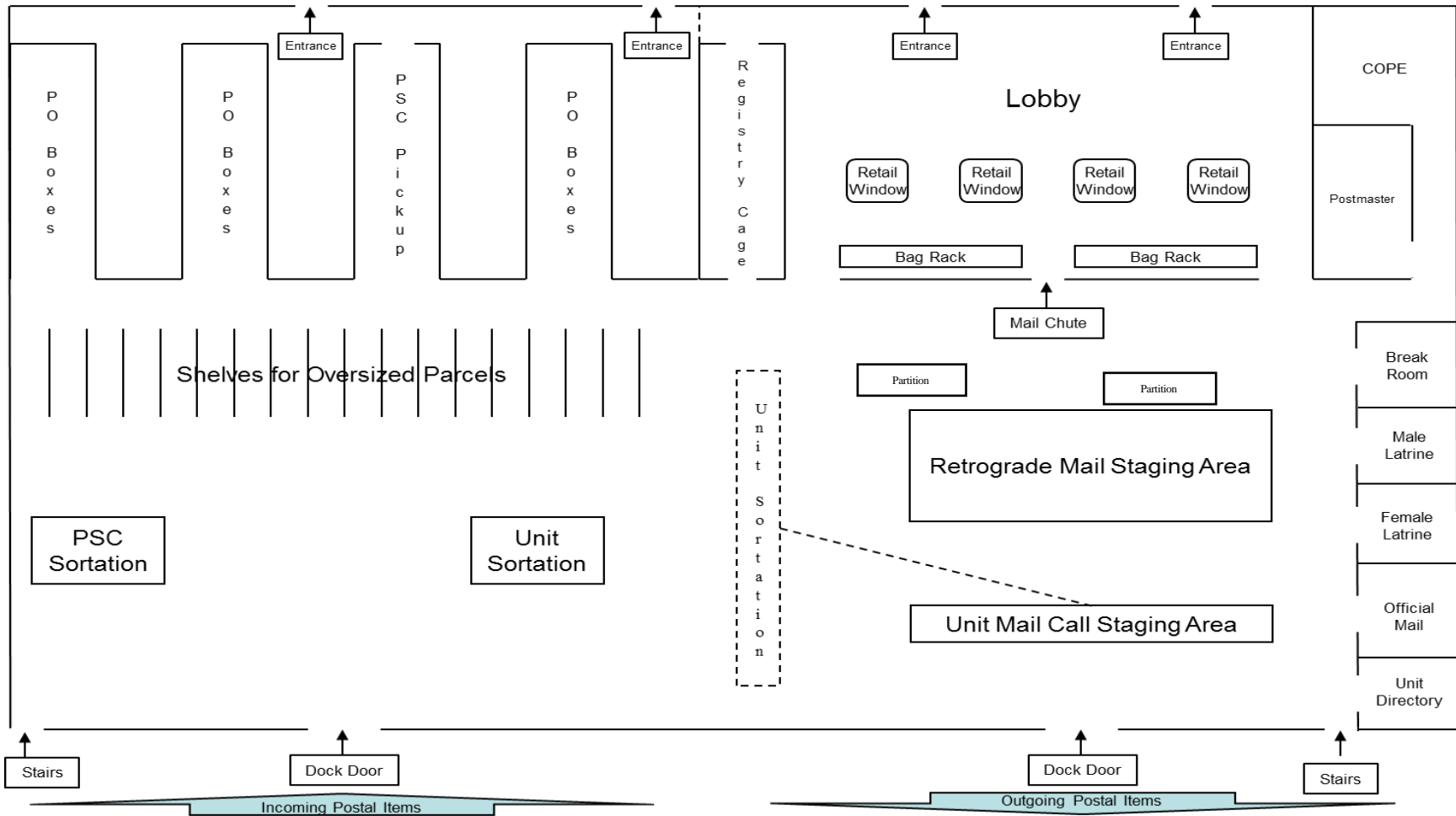

*Note: The layout above is not a requirement; it is a design to assist in determining MPAs requirements. Refer to 15.2.h. for additional planning considerations.

APPENDIX 15C: FACILITY AND EQUIPMENT UPGRADE/IMPROVEMENT PLAN

15C.1. General.

a. The plan identifies improvements and allocates resources during the planning, programming, budgeting, and execution process to address shortcomings and is updated annually.

b. Postal facilities that do not meet the overall net square feet requirement are considered unsatisfactory.

c. Consider postal equipment replacement: belts, rollers, sorters, delivery receptacles, pitching cases, carts, pallet jacks, scales, forklifts, scanners, and retail postage meters with accessories including maintenance agreements, software, and supplies. This equipment may be requisitioned on PS Form 7381 available in AMPS, through the MPSA managed USPS budget.

15C.2. Requirement.

a. The plan shall include a cost-effective investment strategy supporting the activity's mission, complies with the Americans with Disabilities Act, reduces manual processing, replaces worn-out equipment, improves facility appearance, size, and operational efficiencies.

b. Upgrade pre-existing buildings with a self-contained Heating, Ventilation, and Air Conditioning system with an overpressure system to prevent cross contamination in the event of a contamination event.

APPENDIX 15D: CONTINUITY OF OPERATIONS (COOP) PLAN

15D.1. General.

a. The COOP plan is developed IAW DoDI 3020.42. Identify and manage risk to COOP plan using mission assurance construct found in DoDD 3020.40 and DoDI 3020.45. Include OPSEC considerations IAW DoDD 5205.02E.

b. The COOP plan assumes the current facility is inoperable for a period of time due to a natural disaster or man-made event and designates alternate locations or means, e.g., transportation and manpower, to ensure continued postal support.

c. The plan addresses multiple types of disasters or events and responses such as contamination, explosion, fire, water, wind, earthquake, employee strike and hostage.

d. Based on the type of disaster or event and period of time consider resources to reestablish operations: Facility, personnel, computers, copiers, printers, postal equipment, furniture, communications, personal protective equipment, screening equipment and internet connectivity.

e. Consider salvaged equipment and supplies from inoperable facility and postal equipment for reestablishing operations such as USPS retail equipment, postage meters with accessories, software and supplies, belts, rollers, sorters, delivery receptacles, pitching cases, carts, pallet jacks, scales, forklifts, and scanners.

15D.2. Requirement.

a. Postal facilities will have a COOP plan and a communication strategy for affected patrons or strategic partners.

b. The COOP plan must be written, updated annually, disseminated to and exercised annually with all employees and emergency responders.

c. Maintain mobile postal processing kits, less retail equipment, and stamp stock, to reestablish operations for worst case scenario.

d. Submit PNA within 12 hours of facility inoperability.

APPENDIX 15E: FACILITY HOUSEKEEPING STANDARDS

15E.1. General.

- a. Maintain MPA facilities, and equipment in safe and efficient working order, and initiate repairs in a timely manner.
- b. Keep work areas neat and orderly, maintain halls and floors free of slip and trip hazards. Remove waste materials (e.g., paper, cardboard) and other hazards from work areas.
- c. Ensure work areas are not used as storage areas; supplies should be moved to and from the work areas as needed.

15E.2. Requirements. MPAs should refer to the following USPS publications for guidance and assistance:

- a. USPS Handbook, Maintenance Series (MS)-10, Floor, Care and Maintenance.
- b. USPS Handbook, Maintenance Series (MS)-47, Housekeeping Postal Facilities.
- c. USPS Manual, Administrative Support Manual, Section 533.5 (Building and Grounds Cleaning).

SECTION 16: EQUIPMENT AND SUPPLIES

16.1. General.

- a. USPS equipment and supplies are managed through AMPS. MPAs should maintain ample quantities of postal forms, labels, supplies, and equipment based upon their mission.
- b. Prior to requesting retail equipment, MPAs should consider available commercial internet, telecommunication connectivity, and infrastructure.
- c. Prior to requesting supplies, MPAs should consider the population served, the mail volume and composition and length of the mission.
- d. MPAs should exhaust options to replenish supplies within a geographical area, and between Military Services before requesting additional supplies.
- e. A deployment pre-pack kit consists of a modular supply of designated items to support mission requirements. The pre-pack kit item quantities are based on the mission length and population supported. Pre-pack kits do not include stamp stock or accountable equipment.
- f. USPS equipment should be ordered 60 to 90 days prior to deployment.
- g. USPS supplies should be ordered 30 days prior to deployment.
- h. MPAs will submit PS Form 1590 transfer or maintain hand-receipt support documentation in AMPS to demonstrate current and positive control of accountable equipment.

16.2. Requirement.

- a. MPAs will use FEDSTRIP to purchase postal supplies in AMPS from the Universal Items List (UIL) or on a PS Form 7381 and manage on a PS Form 1586 in AMPS. MPAs should contact the JMPA to request adding items to the UIL in AMPS.
- b. Postal supplies will be physically inventoried during the months of January and July. Maintain a 1-month but not more than a 3-month level of supplies, MPAs should consider population supported, routine/peak usage, and resupply timelines.
- c. MPAs will account for serial numbered MPSA and USPS equipment on PS Form 1590 in AMPS. Inventory accountable equipment on PS Form 1590 annually, during inspections, audits and change of custody. Deployed personnel will conduct audits quarterly.
 - (1) A joint, itemized inventory will be performed by the incoming and outgoing PFO, COPE/SC, prior to a custody transfer.
 - (2) Once each item is accounted for, the incoming PFO or COPE/SC will endorse the PS Form 1590 in AMPS.

(3) MPAs must complete a Postal Report in AMPS for all damaged, lost or missing equipment IAW Section 35 this manual upon discovery not to exceed 72 hrs.

(4) MPAs will coordinate with the SCC and JMPA, to resolve accountability, and PS Form 1590 actions involving all damaged, lost, or missing equipment.

d. MPAs will initiate PS Form 1590 transfer actions in AMPS for USPS and MPSA accountable equipment in the possession (either permanent or semi-permanent) of an activity (different ZIP Codes) other than that of the responsible PFO or COPE/SC.

e. Hand-receipt support documentation is required in AMPS for accountable equipment maintained by an activity (subordinate or annex facility or function) organizationally aligned (same ZIP Code) with that of the responsible PFO or COPE/SC.

f. Unit funds will be utilized to procure organizational equipment and supplies, e.g., desk, chairs, telephones, etc.

g. Pre-pack kits will be inspected annually. Replace obsolete items as specified per USPS postal bulletins or MPSA guidance.

SECTION 17: MOBILE ROUTING INSTRUCTIONS

17.1. General.

- a. Routing instructions are used to ensure mail is sent to the correct location.
- b. Planning for postal support to ships and mobile units requires continuous monitoring of movement by the Military Services along with dispatching and receiving activities.
- c. Fixed land-based activities submit a request for a mobile routing address.
- d. Ship and mobile units submit continuous updates to coincide with movements.
- e. Initial MRIs for ships should be submitted 30 days prior to ships move aboard date. MRIs for mobile units should be submitted up to 45 days in advance but no less than 30 days prior to the deployment date.
- f. For postal items arriving after mobile unit departure contact Navy mail router or refer to the AMPS Consolidated Deployed Units Report for disposition.

17.2. Requirement.

- a. Submit mobile routing address requests through AMPS. Only approved addresses will be activated in USPS systems. Do not disseminate addresses for use until personnel, facility, equipment, and transportation are in-place and ready to accept, secure, and process the mail at the deployed location, and active in USPS systems.
- b. Ensure MRIs remain current.
- c. SCC will submit a SMITR for a new geographical location to MPSA-TR. MPSA will establish transportation lanes for new locations requested prior to MRI approval.
- d. Submit an MRI update request at least ten days prior to the effective date of change.
- e. MPSA/JMPA will ensure daily postal routing changes are processed in USPS Military Distribution Table Management System via AMPS interface or manually.
- f. MPSA will validate updates, additions and deletions are recorded in the AMPS Consolidated Deployed Units Report.

SECTION 18: MANAGEMENT OF DELIVERY RECEPTACLES

18.1. General.

- a. Provide delivery receptacle for patron mail pick-up. Common access areas such as patron delivery receptacle areas should be opened for 24-hour access.
- b. The preferred delivery receptacles are those with combination locks.
- c. MPAs that deliver mail through delivery receptacle may use a virtual address for temporary duty and newly assigned personnel until a permanent resident address is established. Permanent addresses must be established within 30 days.
- d. Appropriated funds shall not be used to rent USPS PO Boxes for official or personal use.
- e. The MPAs and individual delivery receptacles will not be used to deliver items for commercial shippers, unless received through USPS/MPS mail channels.

18.2. Requirement.

- a. MPAs will maintain individual delivery receptacle records in AMPS and provide assignment, update, and closure services as required for authorized patrons. Use DD Form 2262, when MPSA approves manual delivery receptacle records.
- b. Individual delivery receptacles will not be used to distribute personal and organizational flyers, pamphlets, or materials. Only mail bearing postage, IDS correspondence, official postal notices, or material the installation commander deems vital (i.e., Security and Force Protection service announcements) may be placed in receptacles.
- c. Number delivery receptacle vertically from top to bottom, in rows either left to right or right to left.
- d. Do not duplicate delivery receptacle numbers when installing new delivery receptacles. Coordinate new numbers with the servicing MPA prior to installation.
- e. MPAs will update individual delivery receptacle information NLT one-business day from the date of the customer's request.
- f. Assign the longest unused delivery receptacle first, except when a section, row, or individual delivery receptacle is removed from service.
- g. Do not assign a delivery receptacle to more than one person. Consider a sponsor and authorized family members as one person. When each member of a married couple has MPS privileges by their military or civilian status, each may be assigned a separate delivery receptacle even if the couple is assigned to the same location; however, encourage them to share a delivery receptacle. If a mailbox shortage does occur, the MPA retains the right to rescind a delivery

receptacle of a dual sponsorship family to support deficiencies due to over population.

h. A command sponsor may obtain a delivery receptacle through formal request for an incoming patron not earlier than 45 days prior to arrival if sufficient delivery receptacle are available for issue. Attach the completed DD Form 2258 to the delivery receptacle. Show the due date and draw a red diagonal line across the face of the form to indicate that the sponsor is due to arrive. Issue a delivery receptacle at either the MPO of duty assignment or housing location where government quarters are assigned.

i. Label the rear of each assigned delivery receptacle with the sponsor's last name. If a family member living with a sponsor has a different last name, both the sponsor's and the family member's name must be on the label.

j. Delivery receptacle numbers issued to overseas retirees or limited services for in care of sponsor are coded with the suffix "R" for example 2356R. Retirees must comply with local host- country customs restrictions. U.S. military retirees must complete a statement acknowledging understanding of their limited MPO privileges (template available in AMPS, Knowledge Management).

k. Postal item addressee must match a name on the delivery receptacle. When names do not match, route the mail to the directory Section for processing. Do not deliver items addressed to "Occupant" or "Resident" or "Commander of" a delivery receptacle number. Endorse with "Insufficient Address" and return the items to the servicing post office for proper handling.

l. MPAs will use PS Form 3907 and notification tools located in AMPS to notify patrons of postal items available for pickup. Prepare the form the same day the article is sorted for delivery. Store the non-accountable articles that are too large for the delivery receptacle for easy retrieval. If MPSA approves use of the manual PS Form 3907s, MPA personnel will enter the storage location, delivery receptacle number, date, and last name of the addressee on the form; forms should be reused.

m. Check each assigned delivery receptacle monthly for mail 30 days past the date of receipt, accumulation, or non-use.

n. If mail is accumulating in a delivery receptacle and a DD Form 2258 has not been filled out, contact the sponsor or the sponsor's commander to determine the sponsor's status.

o. If the status is received from a source other than the sponsor (i.e., Unit Commander, First Sergeant), enter the name and phone number of this source in the "Special Instructions" block of the DD Form 2258. Hold the mail until the sponsor (or appropriate source document) provides disposition instructions; update respective directory record.

p. When patrons do not clear the MPA and provide forwarding address information, mail discovered in the delivery receptacle is returned to the sender endorsed "Unclaimed." Close the delivery receptacle immediately and all mail received thereafter shall be endorsed "Moved – Left no Address," and returned to the sender.

q. PC take the following actions when closing a delivery receptacle:

(1) If not claimed, route remaining postal items for directory services (forward addressing, endorsements, and disposition).

(2) Change delivery receptacle key lock cylinder or combination within five working days of withdrawal. (and/or when the key or combination is compromised)

(3) Record the delivery receptacle closure date, key serial number or new combination, and date of the change in AMPS.

(4) Remove the name label and block the rear of the delivery receptacle with PS Item 0-53A.

r. Maintain originally assigned box-number and designate a temporary delivery receptacle, if the current delivery receptacle cannot be secured and/or repaired within a reasonable time.

s. Update AMPS of unserviceable/non-repairable receptacles with "Do Not Issue."

SECTION 19: PROGRADE POSTAL PROCESSING AND DELIVERY

19.1. General.

- a. Postal processing and delivery to AMS compliant addresses occur in the following ways:
 - (1) At an MPO, through the CPR/PSC section with individual delivery receptacle.
 - (2) At a UPR or OPC, through hand delivery to the mail recipient, their designated representative or individual delivery point.
 - (3) Deliver Cash on Delivery (COD) as regular mail and do not collect postage due.
- b. Patrons will receive personal mail at assigned residence if USPS provides delivery service; otherwise, OPCs or UPRs will deliver.
- c. Mail that is not AMS compliant may be processed as undeliverable as addressed (UAA).
- d. Addressee may control the delivery of their individual mail by completing a PS Form 3801, PS Form 3849, and DD Form 2258 to include other written instructions.
- e. UPR will not require personnel to complete any form i.e., PS Form 3801, memorandums, spreadsheet, etc., to circumvent delivery of personnel mail to a military unit or operation.
- f. Members of the U.S. Armed Forces and their accompanying family members assigned to the Personnel Exchange Program (PEP) may receive mail from the MPO nearest to their PEP duty station.
 - (1) PEP personnel and authorized family members must show a federally issued ID card to receive service and receive mail.
 - (2) PEP participants or authorized sponsored family member must pick up mail at least once every 30 days from the servicing MPO. In extenuating circumstance which prevent PEP members from picking up mail, (e.g., hospitalization, medical illness, or TDY) it is the PEP participants responsibility to notify the post office.
 - (3) PEP participant will not appoint and/or delegate agents to pick up mail.
- g. See Section 23 for processing and delivery of registered mail.

19.2. Requirement.

- a. Postal Processing Standards. Postal received by an MPA shall be processed by date received using a first in, first out methodology as follows:
 - (1) Absentee Balloting Materials, Express, Priority, First Class, Accountable, and IDS

Correspondence will be processed and available within one duty day of receipt.

(2) Standard and Bulk Rate Mail; as well as IDS Parcels will be processed and available within two duty days of receipt.

(3) Redirect items listed in para 19.2.a.(1) above will be returned to the servicing MPO within one duty day of receipt. Items listed in 19.2.a.(2) above will be returned within two duty days. All items to be returned will be back stamped with the date that the item is undeliverable.

b. Process mail addressed to postal personnel the same as mail for other customers. Do not open, store, or dispose of personal mail in the work area.

c. Rewrap or reseal damaged postal items and endorse:

(1) “Received in damaged condition.” Include the date of receipt and identify the unit repairing the article in the endorsement. Claims section will receipt for items that cannot be matched with original packaging using PS Form 3831. If registered OM notify the local security manager if the inner wrapper denotes the contents are classified.

(2) “Received Unsealed.” Endorse officially sealed using PS Label 21 and initial before delivery. If registered OM notify the local security manager if the inner wrapper denotes the contents are classified.

(3) “Opened by Mistake.” Re-seal, endorse, date and sign by the person who opened the mail piece. Deliver the mail piece to the addressee or forward to the correct address.

(4) Postal items with wrappers but missing the contents are processed per USPS Domestic Mail Manual (DMM), Section 507 and USPS Postal Operations Manual (POM), Section 691.4. Loose articles should be matched with an envelope or wrapper. Articles not matched with wrappers will be disposed of as follows:

(a) All loose articles with a value such as pens, pencils, stationery, and personal articles, and clothing will be recorded and disposed locally in the presence of a witness.

(b) Perishable food or tampered personal products are documented and destroyed.

(c) Upon discovery of a rifled postal item prepare and submit a postal report in AMPS.

d. Do not use DoD personnel and resources to duplicate services provided by the USPS.

e. Personal Mail Delivery:

(1) Military personnel, DoD civilians and their command sponsored family members on Permanent Change of Station (PCS) orders receive mail through the End Delivery Point (EDP), e.g., (PSC, CPR, OPC or UPR). General delivery is authorized for individuals on PCS orders at

their local EDP. However, those individuals intending to reside off the military installation or in military housing must provide the EDP a permanent mailing address within 45 days of checking into the local command or mail shall be RTS.

(2) Any designated family member with a valid identification card may receive mail for any family member. Restricted Delivery mail can be delivered to an authorized agent by the addressee.

(3) The sponsor may state in writing that family members cannot have access to the sponsor's mail.

(4) The sponsor cannot control the delivery of mail addressed to the spouse.

(5) The sponsor may control delivery of minor family member's mail.

(6) Mail must be held for addressee who are absent temporarily. Annotate reason for absence on DD Form 2258.

(7) Addressee may refuse unopened mail by writing the word "Refused" on the front of the envelope or wrapper, sign it, and date it. If the addressee declines to make the endorsement, the military PC, UPC or Postal Orderly must write the words "Refused by addressee," date it, and sign it. The postal clerk will return mail refused by the addressee to the servicing post office for disposition by its class. Endorse refused and return to sender (RTS). Un-opened "Return Service Requested" can be returned if refused.

(8) Addressee may refuse accountable mail at the time of delivery, before receiving the article. Endorse "Refused" and RTS. Ensure PS Form 3849 is completed and scanned to indicate item was returned.

(9) For addressees not authorized MPO privileges, RTS, endorse "Addressee Not Authorized MPO Privileges."

(10) General delivery is temporary in nature and will use the virtual box system for addressing and directory. Endorse each piece showing the date received. Do not hold general delivery mail more than 30 days unless information indicates the addressee is due to arrive later.

f. Report postal items suspected of containing hazardous materials immediately to emergency response personnel and in AMPS within one business day.

g. PEP participant must acknowledge their mail responsibilities and sign a PEP Mail Responsibilities Memorandum. Members who choose not to acknowledge their responsibilities will be limited to mailing out services only. (See APPENDIX 19B: PEP Mail Responsibilities Memorandum)

h. After 30 days from the date mail arrived the MPO, unclaimed mail will be returned to sender. MPOs will not redirect or forward mail for PEP personnel via a foreign postal system.

APPENDIX 19A: MPO PROCESSING AND DELIVERY FLOW

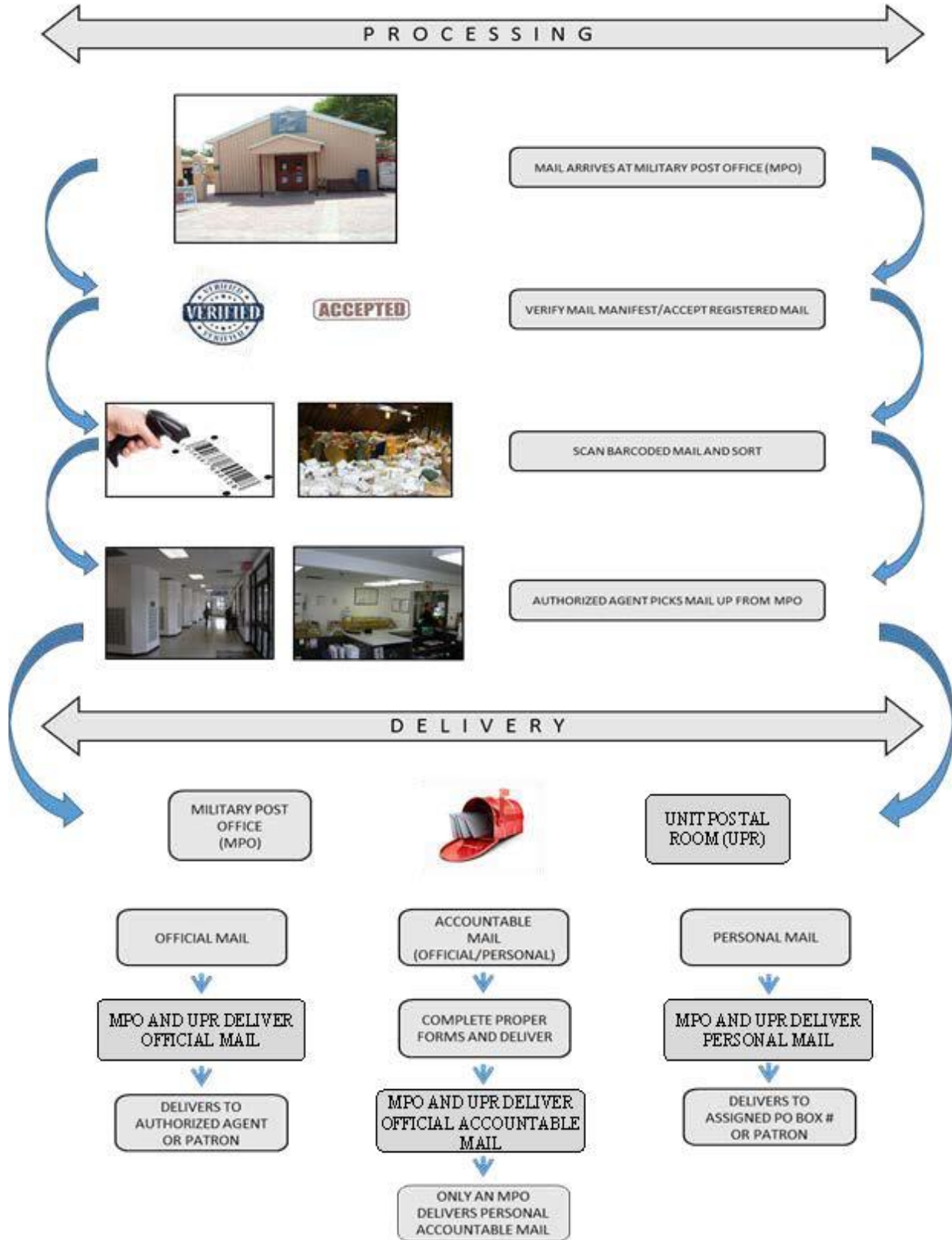

APPENDIX 19B: PEP MAIL RESPONSIBILITIES MEMORANDUM

(USE APPROPRIATE COMMAND LETTERHEAD)

FROM: (PEP Member's Name) Date:
 Box Number
 APO AE 09XXX-XXXX

TO: (MPO Unit Address)

SUBJECT: Personnel Exchange Program (PEP) Participant - Mail Service Responsibilities

1. I _____ as a Personnel Exchange Program (PEP) participant, understand it's my personal responsibility to ensure I or an authorized sponsored family member picks up mail at least once every 30 days from the post office.
2. Myself and my authorized family members must show a federally issued ID card to receive service and receive mail.
3. I will not attempt to appoint and/or delegate agents to circumvent my responsibility to pick up my personal mail at least once every 30 days. If an extenuating circumstance occurs which prevents me from picking up my mail (e.g., hospitalization, medical illness, or TDY), I understand it is my responsibility to notify the post office.
4. I understand that after 30 days, my unclaimed mail will be returned to sender. Mail will not be redirected or forwarded via a foreign postal system.
5. By signing below, I acknowledge my responsibilities and will abide by the policy stated.

SIGNATURE OF MEMBER

DATE SIGNED

PRINT NAME OF MEMBER

CONTACT NUMBER

CONTACT EMAIL

SIGNATURE OF POSTAL SUPERVISOR

DATE SIGNED

SECTION 20: ACCOUNTABLE MAIL

20.1. General. The USPS DMM and POM provide guidance on the processing of accountable mail.

20.2. Requirement.

a. Hold accountable mail for no more than 15 days, unless directed by the addressee.

b. MPAs must conduct Product Tracking and Reporting (PTR) scans on accountable mail in accordance with procedures outlined in and employed through AMPS involving prograde and retrograde [postal](#).

c. Delivery of Accountable Mail (Registered, Insured over \$500, Certified, Signature Confirmation and PMEMS):

(1) Use PS Form 3849 (personal mail) or PS Form 3883 (official mail) for the initial receipt of accountable mail notification. Prepare the form the day the article is received. Deliver a copy of the PS Form 3883 with the accountable mail.

(2) Mark the article with the preparation date on the notice and store it separately from non-accountable articles.

(3) PCs delivering accountable mail will print first initial and last name in the “Delivered By” block of the PS Form 3849.

(4) The addressee or other designated patron must sign and date the PS Form 3811 or PS Form 2865. Check the form for a return address prior to releasing the article and return the receipt to the sender.

(5) Personal accountable mail not claimed within five business days, prepare another PS Form 3849, mark the form to show that it is the final notice, and annotate the new date on the article. Mail not delivered within 10 days of the final notice will be annotated, “Unable to Deliver” and RTS.

(6) Use original final notice or prepare a PS Form 3849 for each undeliverable personal accountable article. Show the disposition on the form. Sign and date the form.

(7) File PS Form 3849 numerically and annually by the last two digits of the identifying article number. Establish a separate file for registered mail if volume warrants.

(8) Return Official and Personal accountable mail to the servicing post office using a PS Form 3883.

(9) UPRs will return undelivered official registered mail to the servicing post office if the facility does not have GSA-approved storage containers.

(10) If the addressee is due to arrive, Temporary Duty (TDY), leave, hospitalized, etc., annotate the PS Form 3849 with “Hold Until (Date)” or forward as directed by the addressee/agent.

d. Process PMEMS as follows:

(1) If not claimed by the third business day prepare and deliver another PS Form 3849 as a final notice.

(2) Use original final notice or prepare a PS Form 3849 for each undeliverable article. Show the disposition on the form. Sign and date the form.

(3) If the addressee is on TDY, leave, hospitalized, etc., annotate the PS Form 3849 with “Hold Until (Date)” and attach to article or forward as directed by the addressee/agent.

(4) If not delivered within five business days after the “Hold Until (Date)” RTS article.

(5) PCs process PMEMS “Waiver of Signature” as follows:

(a) Complete and sign a PS Form 3849.

(b) Annotate “Waiver of Signature” in the Delivery Section of the PS Form 3849.

(c) Maintain the PS Form 3849 IAW postal records retention requirements.

(d) Process and deliver the PMEMS using a PS Form 3907 for articles too large to place in the addressee’s receptacle.

SECTION 21: DIRECTORY

21.1. General.

- a. The USPS DMM, POM, and the DoDI 4525.09 govern address correction and directory service.
- b. General delivery is temporary in nature and used for addressing and directory.
- c. Postal personnel may hold postal items with written consent of the addressee or sender.
- d. Postal directory will not be used as a post, base or personnel locator.
- e. MPAs shall contact local postmaster for Computerized Forwarding System availability.
- f. Customs forms will not be used for directory or forwarding purposes.

21.2. Requirement.

- a. MPAs will use the Directory Module in AMPS to transmit real-time information to the USPS National Change of address online system.
- b. MPAs will maintain directory records in accordance with procedures outlined in, and applied through the directory section within the Operations Module.
- c. MPAs will provide directory service for authorized patrons, including those on TDY or TAD, scheduled to arrive, and permanently departed.
- d. MPAs will not release address information without the sponsor's authorization or per mail cover or search warrant direction.
- e. MPAs will provide address corrections.
- f. MPAs that do not have AMPS directory capability shall follow the manual procedures below:
 - (1) Arrange and maintain directory records alphabetically, by last name, in one file, regardless of status or rank.
 - (2) Ensure directory records are current. Code directory records for destruction and purge closed files older than 13 months (e.g., if a sponsor departs in July 2019, code the directory file for destruction in August 2020). During the first workweek of each month, the MPA must screen directory records and destroy all expired cards.
 - (3) Postal directory records for patrons must contain, as a minimum, name (last, first, and middle initial), grade, organization, mailing address (CPR/PSC number, delivery receptacle

number, and unit) and email address. Annotate the directory record with authorized patron family member's names.

(4) If a sponsor has family members with a different last name, prepare and file a separate card for that family member. Follow this procedure for personnel who have a name change.

(5) Postal directory records for departed personnel must include the date departed, purge date, permanent forwarding address, and a reporting date.

g. MPAs handling mail addressed for sponsors due to arrive must:

(1) Hold the mail for 15 days past the estimated day of arrival. If mail is unclaimed at that time, determine the sponsor's status by contacting the gaining unit or personnel office. If unable to determine status, return the mail to sender endorsed "Attempted - Not Known."

(2) When there is no expected arrival date, contact the gaining unit or personnel office to determine the status. If the individual is inbound, hold the mail for 30 days. If mail is still unclaimed at 30 days, attempt to determine the sponsor's status. If unable to determine status, return the mail to sender endorsed "Attempted - Not Known."

(3) Validate mail held for personnel with the directory section weekly.

h. MPAs must provide priority directory service for mail addressed for "General Delivery." Endorse each piece of general delivery mail showing date of receipt. Do not hold general delivery mail more than 30 days unless information indicates the addressee is due to arrive later.

i. MPAs must provide directory service for confined personnel. Do not annotate confined, brig, or other terms used to identify addressee is in confined status on the postal item.

j. UPCs must endorse and return directory mail to the servicing MPA. MPAs will verify returned mail is properly endorsed.

k. MPAs must not hold mail received from UPCs endorsed "Attempted - Not Known." If the addressee is due to arrive, postal personnel will endorse mail with the arrival date and return to the appropriate CPR, PSC, or UPR.

l. Forward domestic periodical mail for 60 days upon the sponsor's departure. Directory clerks must endorse this mail, "Advise Your Correspondent or Publisher of Your Correct Mailing Address," and, "Change of Address Due to Official Orders."

m. MPA's shall complete a PS Form 3579 for the first copy of a periodical received after a member's departure.

n. For periodicals that arrive after 60 days, directory clerks will input the information in AMPS or send periodicals to USPS Computerized Forwarding Service.

o. MPAs that do not forward undeliverable Periodicals to USPS CFS when received after forwarding service period has expired, will follow the procedures listed below:

(1) Directory clerks will complete a PS Form 3579 for Periodical copies received after 60- day forwarding service period has expired. Endorsed "Change of Address Due to Official Orders." AMPS will produce a member's forwarding address label to affix to the PS Form 3579 for publisher notification.

(2) Complete PS Form 3579, "Undeliverable Standard (A) and (B) and Special Standard Mail (B)" listing the forwarding address and marked "Not Deliverable as Addressed - Unable to Forward."

(3) The PSCs, CPRs and UPRs serviced directly by the USPS must return the Periodical to the servicing post office for processing. List the new address as close to the old address on the Periodical.

(4) MPAs detach the portion of the Periodical containing the old address and mail with the completed PS Form 3579, in a USPS postage-paid envelope, to the sender, with postage due for each form, at least weekly. More than one PS Form 3579 may be mailed to the same addressee in one envelope; however, the postage due must be calculated at the per form rate. Reference to current USPS Notice 123, Price List for rates.

(5) Mail PS Forms 3579 for undeliverable Periodicals, received after the 60 days forwarding service period has expired to the Periodical home office.

(6) MPAs will continue to use PS Forms 3579, Notice of Undeliverable Periodical until supplies are exhausted. Once exhausted, MPAs will use the AMPS, Magazines Attempted Not Known function to input PS Form 3579 actions.

p. The MPAs must dispose of Periodicals received after the expiration of the 60-day forwarding service period. Dispose of undeliverable Periodicals using one of the methods below, remove address labels before distribution:

(1) MPAs may distribute publications to military hospitals, chaplains, dormitories, or recreation services.

(2) Turn periodicals over to the installation-recycling center as salvage paper, or treat them as waste.

q. Forward foreign periodicals received for reassigned personnel for a period of 60 days upon the sponsor's departure. Postal personnel must endorse this mail, "Change of Address Due to Official Orders," and, "Advise Your Correspondent or Publisher of Your Correct Mailing Address."

(1) Forward foreign periodicals for 60 days at no charge, from the effective date of the

sponsor's transfer.

(2) Foreign periodicals received after the 60-day forwarding service period must be handled as follows:

(a) If periodical bears the sender's "request for return," it must be endorsed "Moved, Not Forwardable," and returned to origin.

(b) All other foreign periodicals and any subsequent periodicals received must be disposed of as waste.

(3) The PSCs, CPRs and UPRs serviced directly by the USPS must return the foreign publication to the servicing post office for processing. List the new address as close to the old address on the periodical.

r. MPAs receiving First-Class mail items from a single mailer to obtain directory service must return the mail to the sender endorsed "Insufficient Address." Addresses are insufficient or wrong if there is an obvious incorrect or identical delivery receptacle number.

s. MPAs will return mail to sender if addressed to personnel or organizations that are not authorized MPS privileges. Endorse the mail, "Addressee Not Authorized MPS Privileges." If mail is addressed in care of sponsor, notify the sponsor prior to returning to sender.

t. MPAs must hold mail for Service members who are absent without leave (AWOL) for 30 days. When declared a deserter, postal personnel must:

(1) Endorse first-class, priority, and standard mail, "Moved, Left No Address," and return to sender. Do not mark this mail as "Change of Address Due to Official Orders."

(2) For retail ground mail with return receipts, leave the receipts attached to the article and annotate the reason for non-delivery on the return receipt, initial, and date stamp the card.

u. Postal personnel will process UAA mail IAW USPS DMM and the following:

(1) MPAs will forward mail to the addressee or return to sender. Every effort will be made to locate the individual prior to returning items to sender.

(2) MPAs will provide directory services for priority, first class, standard and package services mail upon the sponsor's departure; this includes retail ground mail and package services that are annotated with either "Address Service Requested" or "Forwarding Service Requested." Forward periodicals for 60 days upon the sponsor's departure.

(3) Write in omitted elements of the name, if known.

(4) Provide directory service for PMEMS and deliver immediately.

(5) Provide directory service for first-class/priority mail within 24 hours of receipt.

(6) Provide directory service for mail received on weekends or holiday no later than the next duty day.

(7) Completely cover barcodes on the front and back of the envelope to prevent the item from “looping” in USPS systems due to automation redirecting based on the barcode.

(8) Endorse neat and legibly, using the minimum space required. Use rubber stamps or gummed labels, if available. Place endorsements on the front of mail. Put the forwarding address below and to the right of the original address. After using available space on the front of the mail, write “Over” on the front and place additional endorsements on the back. Do not write, stamp, or cover the name and address of the addressee.

(9) Include “arrival date” if the sponsor permanently departed and mail is forwarded using a military unit as the forwarding address.

(10) Date-stamp the back of each piece of mail receiving directory service. If directory mail is not processed on the date of receipt, annotate the date forwarded or returned to the sender. If processing a large volume of directory mail, postmark it on the reverse side of the address by machine instead of manually back stamping.

v. If mail is spoiled upon receipt, notify the sender or addressee when disposing of the item using a witness.

w. MPOs and OPCs must follow these procedures for mail that cannot be delivered, forwarded, or returned to sender:

(1) Send all express, first-class (including stamped cards), and retail ground mail to the USPS Mail Recovery Center (MRC) for disposition. Complete a PS Form 3849 showing the disposition of accountable mail.

(2) Periodical handling procedures outlined in this section, 21.2.o. through 21.2.p.(2)(b). Postcards are shredded and disposed locally.

(3) UPRs and CPRs must properly endorse undeliverable postal returned to the servicing MPO, OPC or PSC. Postal supervisors will verify endorsements prior to assuming custody.

x. MPAs will ensure prompt directory service for undeliverable IDS items. Do not forward IDS items if the addressee has been transferred to the U.S., international, or an MPO which requires the item to transit the USPS system. IDS items that cannot be forwarded or returned will be sent to the designated IDS Recovery Office for disposition. Do not send undeliverable IDS to a USPS MRC.

y. Mail for units returned to the U.S. and inactivated units:

(1) MPAs must provide directory service for departing units for a period of 90 days IAW instructions provided by the SCC.

(2) Do not forward periodicals or standard print matter, dispose immediately. Remove personally identifiable information.

(3) MPAs must forward personal parcels and first-class mail for personnel who departed with the unit.

(4) Readdress accountable mail individually, along with completing a PS Form 3849.

(5) MPAs will forward OM. When volume warrants, bundle the mail into direct ties, bag it without individual readdressing, and label it for direct mailing to the unit.

z. Mail for Decommissioned Ships and Disestablished Installations:

(1) The SCC for ships or land-based MPO must designate a MPA to perform directory service. Directory service must be done by the MPA for a 60-day period.

(2) The CO of the ship or installation must inform the mail routing authority or postmaster of the date desired for routing the mail to the MPA that will provide directory service.

(3) The CO of the ship or installations must furnish the designated MPAs with a complete directory file of all personnel, showing the new duty station, or, in the case of those separated from the Military Service, the forwarding permanent address furnished by the member.

(4) The servicing MPA will forward personal mail and deliver OM to designated agent. Postal personnel must not be assigned duties involving the opening and screening of OM.

(5) MPAs will not forward OM addressed to a U.S. ship stricken from the Standard Navy Distribution List and transferred to a foreign government or merchant marine service.

(6) The designated activity must destroy directory files upon completion of the 60-day directory service. After 60-days, endorse "Decommissioned" or "Disestablished", and RTS mail.

SECTION 22: CASUALTY MAIL

22.1. General.

- a. Deliver or forward jointly addressed items when one of the addressees can receive the mail.
- b. Postal personnel work closely with the Casualty Assistance Officer (CAO) who is appointed responsibility to oversee the highly sensitive mission of casualty assistance for service members and their families.
- c. Postal personnel are charged with providing accurate directory services associated with casualty postal items. Under no circumstances is mail for casualties returned to sender or forwarded until verification is received from the CAO that next of kin has been notified.
- d. Endorsements such as “Missing,” “Killed in Action,” “Deceased,” or “Wounded” are never placed on casualty postal items.

22.2. Requirement.

- a. MPAs will hold all postal items for personnel whose duty status is unknown until verification is received.
- b. Only postal personnel trained on procedures for handling casualty postal items are authorized to provide directory service for the postal items.
- c. UPCs will attach a signed memorandum by the CAO, which contains the following information to returned postal items on a daily basis:
 - (1) Rank and Full Name.
 - (2) Unit Assignment.
 - (3) Date of incident.
 - (4) Status Missing In Action (MIA), Captured, Deceased, Hospitalized, or Missing.
 - (5) Address of hospital treating casualty. (If known).
 - (6) Next of kin instructions.
 - (7) Unit POC.
- d. Postal personnel will verify that returned postal items match the (Rank, Name and Unit) information on the memorandum and use the All-Purpose Date Stamp to date each postal item.

- e. MPAs will provide directory service IAW CAO instructions.
- f. Contingency locations will process IAW COCOM procedures.
- g. Return federal government checks to the sender unless hospitalized.
- h. Retain CAO memorandum at MPA for 13-months.

SECTION 23: REGISTERED MAIL

23.1. General.

- a. Postal clerks performing retail services regardless of citizenship may accept personal registered mail.
- b. Official Registered mail may contain classified material up to and including SECRET. Only U.S. citizens possessing an interim or adjudicated SECRET clearance will receipt for, process, and transport Official Registered mail; and/or be assigned to Registry Section including supervisory duties.
- c. Registered mail must be secured at all times. Items will be stored in an approved GSA container. While not in a secure location, keep item under surveillance.
- d. Registered mail will be dispatched on non-stop commercial US flagged carriers or DoD aircraft, never on foreign flagged code share partners.
- e. MPAs will:
 - (1) Limit access to registered mail working section to personnel assigned to registry section and authorized inspectors in an official capacity.
 - (2) Scan PS Label 200 “Registered Mail” and select the PTR event code.
 - (3) Establish procedures with the designated air carriers to immediately notify the military any time a designated flight diverts, overflies, or returns to the airport of departure for any reason.

23.2. Requirement.

- a. Maintain an unbroken chain of receipts.
- b. Accept personal registered mail using PS Form 3806, or official registered mail on PS Form 3877. Official registered mail is returned to the servicing MPA from a **UPC** using a PS Form 3883.
- c. Deliver personal registered mail using PS Form 3849, or official registered mail on PS Form 3883.
- d. Transport registered mail using a PS Form 3854 as the custody-transfer document in combination with the following transportation document and procedures:
 - (1) Ground transportation: Receptacles will be placed in vehicles or trailers with an approved GSA approved locking device and USPS Registered Mail (numbered) seal. The MPA will prepare a DD Form 1372-E, and annotate the Registered Mail seal number in Item #25 of

the DD Form 1372-E.

(2) Air transportation: Receptacles will be affixed with a USPS Registered Mail (numbered) seal, and the Registered Mail seal number annotated on the PS Form 2942-A (for commercial transportation) or DD Form 1384 (for AMC transportation).

*Note: MPA Supply clerks may order USPS Registered mail (numbered) seals through the Supply Module in AMPS.

e. A U.S. citizen must accompany official registered mail when being transported by truck.

f. MPAs complete a PS Form 3826 for irregularities detected in the preparation, or acceptance of Registered Mail articles and notify the responsible activity.

g. Ramp watch is conducted by US citizen at foreign airports where DoD is authorized to physically monitor flights:

(1) Request air carrier provide information on which Unit Loading Device contains registered mail.

(2) Keep the Unit Loading Device or loose registered mail in view at all times.

(3) Accept custody of registered mail planeside when possible. Escort and retain visibility of mail during customs processing.

(4) Maintain visual contact of registered mail during dispatching, loading operations, and until the aircraft is completely closed.

h. MPAs generate a DD Form 2261 in AMPS showing registered mail transactions and on-hand inventory.

i. MPAs receiving missent registered mail will scan as “missent.” Nest and dispatch for onward movement.

j. MPAs receiving registered mail without PS Form 3854 will create one and endorse “Items received without PS Form 3854.” Scan item “arrived.” Email originating MPA a PS Form 3854 with remarks identifying the issue. Deliver or re-dispatch as necessary.

k. Create PS Form 3854, endorse “Found in Ordinary mail at (location)” when found comingled with other mail. Scan item “arrived.” Email the MPA of origin a copy of the PS Form 3854 with remarks identifying the issue. Deliver or re-dispatch as necessary.

l. For registered mail found at a location that has a registered mail restriction, the MPA shall coordinate with higher headquarter for guidance regarding the re-dispatch procedures.

m. International registered mail “found in ordinary mail” will be processed as accountable

mail to obtain a signature at the time of delivery, unless received from USPS as registered mail. In this case process as registered mail.

- n. Redact information on packaging indicating high value.
- o. All personnel will be escorted in the registry area, and annotated on a PS Form 1625. PCs will record opening and closing registry cages and safes using a SF 702.
- p. At-sea, registered mail will be transferred in weighted, non-watertight bags to ensure sinking in case of loss. Refer to Navy Warfare Publication.
- q. MPAs submit a postal report for registered mail compromises or suspected compromises including recoverability and report to local security personnel.

SECTION 24: RETAIL MANAGEMENT AND OPERATIONS

24.1. General.

- a. USPS software and retail equipment are used to manage flexible credit accounts. Follow the guidance provided in AMPS, under Documents, in the Knowledge Management module.
- b. Stamp stock is advanced by the USPS Stamp Distribution Center (SDC) to the PFO or COPE/SC.
- c. The PFO, COPE/SC credit limit requests are routed through the chain of command.
- d. Acceptance of personal checks for postal services is determined by the SCC. MPOs accepting checks must display pertinent personal check acceptance requirements and information in the retail operations area.
- e. The term "remittances" refers to a method of payment. Submit remittances via Electronic Funds Transfer, Bank By Mail or DoD Community Bank for deposits.
- f. Mailers are responsible for placing contents inside and affixing postage on mail items. Postage must be affixed to mail as described in USPS DMM. PCs must cancel stamps in full view of the mailer upon acceptance. PCs will apply machine-generated postage in full view of the mailer.
 - (1) MPAs pick up, postmark, and dispatch postal items from USPS collection boxes every day the facility dispatches mail. Maintain accurate service and dispatch information on the Dec 55-B, Card, Collection Time label affixed to the collection box. In addition to Label DDD1, ATTENTION Mail Collection Policy which requires postal items over 10 ounces to be brought to the MPO finance counter.
 - (2) Mail is postmarked at the time of acceptance and dispatched no later than the following duty day unless host nation, or air/ground carrier schedules restrict dispatch movement.
 - (3) Service electronic canceling machines and manual stamps daily according to manufacturer instructions, to ensure postmarks applied are legible and indicate the current date.
- g. PCs will not act as intermediaries for customers in the performance of retail service duties, or handle funds other than those to transact postal services.
- h. All forms of customer payment must be drawn from US currency.
- i. Items mailed in USPS provided packaging available at MPOs must be charged the designated mail rate of the packaging.
- j. PCs have the authority to refuse parcels that contain non-mailable items, or sufficiently

packed to withstand the transportation environment. These responsibilities are defined in the USPS DMM, Section 600, Basic Standards for All Mailing Services.

24.2. Requirement.

- a. Credits, Accounts and Stamp requisitions are created in AMPS.
- b. PFO, COPE/SC will follow the guidance per USPS Handbook F-1 and F-101 for establishing MPO Credit, financial transactions and accounting. The SCC establishes the initial credit limit.
- c. Personnel performing retail operations will complete the following training in AMPS Knowledge Management annually:
 - (1) Processing procedures for PS Form 8105-A, Funds Transaction Report (FTR) and PS Form 8105-B, Suspicious Transaction Report (STR) actions.
 - (2) AMPS Bank Secrecy Act (BSA) and Anti-Money Laundering On-Line Training annually or when training has been updated.
- d. The following will determine the initial MPO credit:
 - (1) Transit times between the MPO and the credit source.
 - (2) Availability of a postage meter machine.
 - (3) Population serviced.
- e. Establish and manage assigned stamp stock and cash credits and conduct timely reconciliation of all credit accounts.
- f. Order bank deposit slips in AMPS. Use original pre-printed bank deposit slips to submit remittances. Coded bank deposit slips denote each account. Deposit slips are not interchangeable between accounts.
- g. Retain one copy of the deposit slip with the duplicate copy of the PS Form 1412 in the PFO or COPE/SC files.
- h. Payment card industry terminals (credit/debit card machines) will be inspected and annotated daily for each terminal prior to the unit opening.
- i. Payment card industry terminals (credit/debit card machines) will be inspected using the quarterly record of inventory procedures in AMPS Knowledge Management.
- j. MPO Credit Operations:

(1) The PFO, COPE/SC signs PS Form 17 within the stamp shipment as the person receiving stock and must have a witness signature.

(2) The PFO, COPE/SC physically matches the stamp inventory against the PS Form 17.

(3) The PFO, COPE/SC issue cash credit.

k. Establishing Clerk Credit:

(1) The PFO, COPE/SC will initiate a PS Form 17 in duplicate to establish a credit from PFO or COPE. IAW USPS F-101 the responsible commander must authorize, in writing, window clerks to retain fixed credits in excess of \$1,000.

(a) Maintain stamp credits to a reasonable multiple of the PC's weekly sales amount. A 2-week multiple is recommended. The PFO, COPE/SC may adjust the value of stamp credits to be consistent with customer demand.

(b) The cash portion of a stamp credit must not exceed 10 percent of the stamp credit or \$100, whichever is less.

(2) PC will validate the stock received matches the amounts on the PS Form 17, and if item number, quantities, and values match, signs as the person receiving stamp stock. PFO or COPE/SC signs as the witness. If the item number, quantities, or values do not match, then the PC needs to resolve the matter with the PFO or COPE/SC that issued the stock. PFO or COPE/SC retains a signed copy.

(3) The PFO, COPE/SC completes and retains the PS Form 3368-P.

(4) The PFO, COPE/SC will annotate the amount of cash being issued to the PC and record on PS Form 3544 in duplicate (Manual Operations Only). The PC will count the cash and sign both copies of PS Form 3544. One copy will be maintained by the PFO or COPE/SC and the other copy will be given to the PC. RSS locations will follow the workflow for cash transfers in the RSS procedures guide.

(5) PC with a stamp credit who is not scheduled for window duty within 15 consecutive calendar days must remit the entire credit to the PFO or COPE/SC.

(6) Issuing Money Orders:

(a) The PFO, COPE/SC will not split blocks of domestic money orders between PCs.

(b) The PFO, COPE/SC at a manual office issue money orders using DD Form 885. RSS offices will use the appropriate workflows.

(c) The PC must verify the continuity of money order serial numbers in the presence of a witness.

(d) When an PC credit is withdrawn, the assigned money orders are counted by the PFO, COPE/SC in the presence of a witness and returned to the COPE/SC stock and recorded on DD Form 885. Only then may money orders be reassigned to another PC within the same unit.

l. MPAs will have Retail Clerks complete a Daily Money Order Tracking Log each day for money orders sold to customers. This log will be submitted and filed daily with the Retail Clerks PS Form 1412. A template of the Daily Money Order Tracking Log, and instructions are available in AMPS, Knowledge Management.

m. RSS offices must close the unit at the end of each business day.

n. Manual offices must enter the PS Form 1412 data into AMPS at the end of each business day.

o. Record expected closures in AMPS. COPE/SC are required to e-mail the USPS Field Sales Branch (FSB) Office and respective SCC anytime there is an interruption of finance service or when the post office will not be opened on a regularly scheduled business day.

p. Verify final PS Form 1412 with USPS accounting office prior to initiating closure of MPO.

q. Upon closure of an MPO, forward completed USPS financial records and DD Form 885 to the servicing PFO or COPE/SC. All stamp stock and MOs will be returned to the USPS Stamp Distribution Center IAW USPS Handbook F-101, Chapters 11 and 13. Return USPS equipment IAW USPS and DoD established procedures.

SECTION 25: AUDITS

25.1. General.

- a. The USPS Handbook F-1 and F-101, Chapter 13 provide guidance on conducting audits.
- b. Audits performed by the USPS, MPSA, DoD and Service Audit Agencies, Service Inspector Generals, or Service postal staffs meets the annual audit requirement.
- c. Agents authorized to perform audits.
 - (1) Representatives of the USPS Postmaster General and MPSA.
 - (2) DoD and Military Service Audit Agencies, including the Monies Audit Board members.
 - (3) Persons whose duties are of an investigative nature, when authorized by the responsible postal commander or the USPS for a specific purpose.
 - (4) A disinterested officer, non-commissioned officer, and civilian appointed by the responsible postal commander.
- d. Instructions on how to audit Flexible Credit, Money Order, and Postage Meter Accounts are listed in Appendix 25A of this manual, and AMPS Knowledge Management.
- e. During audits, individual credit accounts do not require an additional audit when a shortage or overage occurs that is within USPS Handbook F-101, Chapter 13 tolerance limits. Carry these differences forward to the next audit.
- f. Personnel may be relieved if they consistently show excessive overages or shortages from duties that involve the handling of postal effects.

25.2. Requirement.

- a. Conduct audits at unscheduled and unannounced times. At no time will a self-audit be conducted.
- b. The SCC or their representative will conduct annual audit.
- c. The Postal Officer or MPO Supervisor will ensure the COPE/SC change of custody audits are conducted.
- d. The person audited will be present during the audit. In case of absence (i.e., AWOL, unauthorized absence, illness, regular day off, etc.), another person will witness the audit.
- e. Personnel conducting the audit will not have unescorted access to the account being

audited prior to or during the audit.

f. Ensure the frequency of PFO, COPE/SC, and Unit Reserve account audits IAW USPS F-1 and F-101 Handbooks guidance.

g. All PC accounts shall be audited at least once monthly. It is recommended that newly assigned PC accounts be audited weekly for the first 30 days.

h. Conduct additional audits of accounts and postal effects:

(1) When the structural integrity of the MPA is compromised.

(2) Following deployments, combat, theft, unsecured facility or discovery of unsealed duplicate key or combination envelopes.

(3) After man-made or natural disasters.

i. Recoup shortages from PFO, COPE/SC on transferred accounts. If recoupment is not possible, refer this matter to MPSA for resolution.

j. Reserve custodians with stock will participate in the audit. Inventory and sign a new designation letter and PS Form 1590 for USPS accountable effects.

k. Maintain a consolidated listing of audits on PS Form 3368-P and provide comments in the "Remarks" section:

(1) If PFO, COPE/SC accounts are out of tolerance, all clerk accounts will be audited.

(2) Auditors may authorize the transfer of funds between the primary and sub accounts using PS Form 3544 if either account is out of tolerance, and can offset the other account. Record this transfer in the "Remarks" section of each PS Form 3294.

(3) Contact MPSA if PFO, COPE/SC account overages or shortages are identified as being out of tolerance, for manual operations.

(4) Identified PFO, COPE/SC account shortages must be reconciled prior to transfer of accountability.

(5) When auditors determine PFO, COPE/SC primary accounts are in tolerance, then the clerk accounts do not need to be audited, and differences are carried forward to the next audit.

(6) An additional audit may be conducted at the request of the individual being audited.

(7) Postal Officers and MPO Supervisors must exercise judgment when determining the existence of a relationship, which may warrant an offset of an overage and a shortage; and maintain appropriate documentation locally. Likewise, monitor and pursue collection of

shortages (debt) while adhering to the applicable debt collective procedures in the event of refusal to make restitution or criminal intent is suspected.

l. Auditors and audited MPAs will maintain a copy of PS Form 3294. File PS Form 3294 with inspection reports when audits are conducted in conjunction with inspections.

m. SCCs, PFOs and COPE/SCs shall maintain audits and records within their purview and will retain financial and administrative records IAW DoD and USPS records management policy.

APPENDIX 25A: HOW TO AUDIT MPS ACCOUNTS

Table 1: How to Audit a Fixed Credit Account

Step	Instructions
1	Complete the heading of PS Form 3294, "Cash and Stamps Stock Count and Summary." Determine the amount of fixed credit advanced to the individual by checking the PS Form 3369 issued by the person advancing the fixed credit.
2	Using pages 2 of 4 and 3 of 4 of PS Form 3294, inventory stamps, paper stock, cash funds, and requisitions in transit.
3	Show inventory results in the "Summary of Accountability" section of the PS Form 3294. Auditors will honor letters explaining shortages in receipt of stock from the source of supply. The amount of shortage will be added to the actual stamp stock on hand with an explanatory note placed in the "Notes, etc., Remarks" section of the audit form.
4	If an overage or shortage exists, see Summary of Accountability, block 23.
5	Review MO accounts and record required data on PS Form 3294.
6	Audit postage meter account and record balance on PS Form 3294, block 11.
7	When auditing a PFO or COPE, the auditor will review the last PS Form 3294 to determine if any outstanding shortages exist. Outstanding shortages will be recorded on each subsequent audit form until the shortage is replaced.
8	Record the results of the audit on the PFO or COPE/individual's PS Form 3368 and keep PS Form 3294 on file at the postal activity.
9	When auditing a PFO or COPE, the auditor will inventory all capital sensitive equipment listed on the activity's PS Form 1590, "Supplies and Equipment Receipt." Report any missing items as a possible postal offense or loss to higher headquarters. Document the shortage in the "Notes, etc." section of PS Form 3294 and AMPS
10	When auditing a COPE, the auditor will provide the responsible PFO with a copy of PS Form 3294.
10a	The PFO reviews the audit sheet to verify amount(s) entered for in transit stamp requisitions and immediately notifies the auditor of any discrepancies, e.g., amount of in transit stamp requisition reported does not agree with amount(s) received, stamp requisition reported not received, etc.
10b	The auditor will verify the check number and the amount listed on the file copy of PS Form 17, with the check-issuing activity. The auditor will then verify the registered dispatch documents.
11	Check PS Form 3977 duplicate key envelopes.

Table 2: How to Audit a Flexible Credit Account

Step	Instructions
1	<p>Complete the heading PS Form 3294 by indicating Main or Reserve Stock, Stamp Credit, or check the Other (Specify) block (i.e., account turnover).</p> <p>a. Type of accountability:</p> <ul style="list-style-type: none"> (1) Main or reserve - PFO/COPE/Finance Supervisor. (2) Stamp credit - use for clerk account. (3) Cash retained - reserve and Unit - should not be used. (4) Other - used to indicate vending accounts. <p>b. Name of employee - enter name of account holder.</p> <p>c. Clerk identification (ID) No. - ID # assigned by COPE/Finance Supervisor.</p> <p>d. Unit name - name of unit being audited.</p> <p>e. Unit ID No. - standard field accounting number assigned by Field Sales Branch Management Team.</p> <p>f. Date of examination - audit date.</p>
2	<p>Cash and items on hand - enter the quantity and amount and enter the total in item 26. Items 27-32 are completed as applicable. Total items 26-32 and transfer the totals to item 33.</p>
3	<p>Summary of accountability</p> <p>Line 1 - Enter total cash and cash items on hand from line 33 column II.</p> <p>Line 2 - Enter any paid-out items listed on PS Form 3533 in column I, if applicable.</p> <p>Lines 3-5 - Complete if applicable (If any entry is on line 2 column II, line 5 column II will be completed).</p> <p>Line 6 - List any amount recorded from column II line 1, in column II.</p> <p>Lines 7-13 - Complete if applicable.</p> <p>Lines 14-16 - List the total accountability of extend credits from the COPE or Finance Supervisor account.</p> <p>Line 17 - Enter the totals for any items entered in lines 6-16.</p> <p>Line 18 - Enter the totals from pages 2 of 4 and 3 of 4 in column I.</p> <p>Line 19 - Complete if applicable in column I.</p> <p>Line 20 - Complete if applicable in column II.</p> <p>Line 21 - Enter the totals from line 17 and 20 column II.</p> <p>Line 22 - List the amount recorded in AICs 840 or 353 from Form 1412. (Information must be obtained from AMPS, Unit Online 1412).</p> <p>Line 23 - Record the differences between lines 21 and 22. (For PFO, COPE, or Finance Supervisor accounts, the tolerance is zero).</p> <p>Line 25 - Check the appropriate box. (For military units, the Form 571 will not be completed.)</p> <p>Lines 26-32 - See #2, above.</p>
4	<p>Check PS Form 3977 duplicate key envelopes.</p>

Table 3: How to Audit a Retail Systems Software (RSS) Account

Step	Instruction
1	Utilizes RSS Military Procedures Guide to audit PFO/COPE/Clerk account. Location: Knowledge Management→ Documents→ RSS INFORMATION. (Handbook F-101, Field Accounting Procedures Section 13-8 Conducting Cash Counts and Section 14 Segmented Inventory Accountability, and the RSS Guide chapter 7.4 Counts.)
2	When auditing a PFO or COPE, the auditor will inventory all capital sensitive equipment listed on the activity's PS Form 1590, "Supplies and Equipment Receipt." Report any missing items as a possible postal offense or loss to higher headquarters.
3	Check PS Form 3977 duplicate key envelopes.

Table 4: How to Audit a Money Order Account

Rule	If PFO	If COPE	If MO Clerk	Then:
1	X	X		Compare PS Form 17 (Stamp Requisition) with serial numbers, broken or unbroken sets, or boxes.
2	X	X	X	Compare serial numbers of issued money order sets listed on DD Form 885 with PS Form 17.
3	X	X	X	Check sequence of issuance or transfer of blank set on DD Form 885.
4		X	X	Compare PS Forms 17, DD Form 885, Final 1412s, and money order set blanks on hand, to ensure that all are accounted for.
5		X	X	Verify money orders on hand against DD Form 885 and Form 1412.
6		X	X	Ensure Unit 1412s are transmitted daily.
7		X	X	Verify postal funds are deposited daily by checking the bank deposit slips.
If discrepancies are noted or suspected, contact the check-making facility to confirm the amounts and dates which checks, or money orders were issued. Also, registered mail dispatch records can be compared with AMT or FMC records to confirm shipment.				

Table 5: How to Audit a Postage Meter Account

Step	Instructions
1	Verify meter heads on hand against meters documented on PS Form 1590.
2	Verify the "received for postage" computations for ascending and descending balances on PS Form 3602-PO (Meter Book) for each meter on hand and used since the last audit.
3	Verify that the meter clerk transferred meter monies to the PFO COPE on PS Form 3544.
4	Verify that the remittances (bank deposit slip or check instrument) equal the total received for postage, minus any amounts claimed on PS Form 3533.

SECTION 26: SCANNING

26.1. General.

- a. USPS Pub 199 provides guidance for PTR and barcode scanning.
- b. The scanning of Intelligent Mail Package Barcode and postal items with a Label 150 creates a PTR event that is transmitted to AMPS and USPS.
- c. Accountability is ensured by scanning postal items. Scanning provides the means to track postal items and analyze the efficiency of the MPS.

26.2. Requirement.

- a. MPAs will perform scans on arriving and transiting barcoded postal items. Postal items received as working mail will be nested prior to dispatch or manifest.
- b. MPAs will perform the following prograde [postal](#) item scans:
 - (1) MMT - Processed through facility.
 - (2) MPO or OPC - Available for pickup.
 - (3) MPO or OPC Disposition - e.g., Delivered, Forwarded, RTS Unclaimed or Refused.
- c. MPAs will perform the following retrograde and [IDS postal](#) item scans:
 - (1) MPO - Acceptance.
 - (2) MMT or MPO or OPC - Nesting.
 - (3) MMT or Dispatching MPO - Dispatch.
 - (4) MMT - Process through facility.
 - (5) (IDS Only) MPO or OPC - Available for pickup.
 - (6) (IDS Only) MPO or OPC - Disposition (i.e., Delivered, Forwarded, Return to Sender - Unclaimed, Refused, Missent, etc.).
- d. MPAs will refer to the PTR Scanning Decision Flow Chart located in AMPS, Knowledge Management for a current list of required PTR scans.
- e. MPAs will transmit scanned data daily.

SECTION 27: GLOBAL TRADE COMPLIANCE

27.1. General.

a. Nesting is the process of scanning barcoded postal items via AMPS and placing in a transportation receptacle. Outside Pieces (OSP) are considered nested when the barcode is scanned, and the item validated for Global Trade Compliance (GTC) clearance.

b. GTC clearance for postal items is achieved/comprised of three components:

1) Manifesting. Refers to the physical presence of electronic Customs Form data required for all parcels; with the exception of those associated with OM.

(2) AED transmittal. Refers to the transmission of electronic customs data through the AMPS and USPS systems as a result of a prepare to mail transaction via: Click-N-Ship, Customs Form Online, (hardcopy) PS Form 2976-R processing, or data upload in AMPS:

(3) Nesting. The automated process of assigning postal items to mail receptacles for the purposes of dispatch and transportation. An EDL with unique barcode applied as a slide label will provide origin, destination and mail class information; and allows for improved visibility and tracking of the individual postal items.

c. AMPS validates the nested item is GTC compliant and cleared for ground or air transport. Mail that cannot be validated will not be transported to another location for dispatch.

d. MPSA maintains GTC validation notification instructions in AMPS for items not cleared for transport. For items not receiving clearance, GTC instructions will contain disposition information and guidance for the MPA.

27.2. Requirement.

a. MPAs will nest barcoded postal items IAW AMPS Help File by transportation category. Transportation categories and mail flow for each category are located in AMPS Knowledge Management.

b. Postal items with a GTC “Hold” will not be dispatched and transported until cleared. USPS will provide disposition instructions and items not cleared will be returned to customers, or designated agent.

c. Postal items held are divided into two categories:

(1) Manifest Hold. This hold refers to missing or incomplete electronic customs data within the Customs and Border Protection Manifesting System (CBPMAN). Electronic Customs data must be entered as referenced in 27.1 b. 1 & 2.

(2) Compliance Hold. This hold refers to a Customs Office or other authorized agency

issued guidance not allowing the item to be transported.

d. MPAs will develop disposition procedures for postal items not GTC cleared for transport. In addition to requesting disposition instructions from USPIS - Global Security Program Manager and coordinating with local agencies, procedures will include retaining documentation (reference Section 38.1.c. this manual) of postal items returned to the customer or designated agent, donated, or disposed of locally (as directed by USPIS).

SECTION 28: DISPATCH

28.1. General. The USPS ICAIR contract governs dispatching which is executed in AMPS. Procedures for dispatching are in the AMPS Help File.

28.2. Requirement.

a. Postal items will be assigned to air carriers based upon the rankings and guidelines established by the ICAIR contract for each Origin and Destination (O&D) pair. Deviations from these rankings are prohibited without first providing justification to MPSA/approval from USPS.

b. Commercial air carriers are responsible for transporting postal items between the carrier facility and designated military location.

c. MPAs will verify postal items received from commercial air carriers match the flight manifest. Periodically check the air carrier's warehouse and staging areas for delayed or missing postal items.

d. To ensure correct payment for transportation of postal items to end destination, MPAs will use the following guidelines when those items have been transported to the wrong location, failed to transfer/load or were loaded in error:

(1) Do not remove backlogged postal items from air carriers who can perform prompt movement. Otherwise, reassign to another carrier.

(2) MPAs will re-dispatch postal items that were intercepted from one carrier to another carrier. Use the Label 150 to transfer in AMPS-Dispatching.

e. Use DD Form 1372-E or OPNAV 5110/9 in AMPS to manifest postal items transported by ground. When a manifest includes registered mail, attach PS Form 3854. For multi-stop service take the appropriate action:

(1) Complete a PS Form 3854 and DD Form 1372-E or OPNAV 5110/9 for each stop before departing original MPA.

(2) Reseal containers of registered mail and annotate the seal number on the completed DD Form 1372-E at each stop.

(3) The receiving MPA will reseal containers of non-registered mail.

f. Use a PS Form 2942-A to dispatch postal items transported by commercial air. When a dispatch includes registered mail, place PS Form 3854 inside the container. For OSPs, attach an EP-9 containing PS Form 3854.

g. Use the DD Form 1384-E in AMPS to manifest postal items on Air Mobility Command (AMC) and Surface Deployment and Distribution Command (SDDC) transportation.

h. To expedite the processing of postal items, load truck trailers and sealand containers from front to rear by deferred, preferred, expedited, and registered.

i. Annotate the name of the PC who sealed the truck and sealand containers in the mail manifest's remarks; the receiving MPA will verify the seal number matches the mail manifest.

j. Postal items transported by sealand containers adhere to the following procedures:

(1) JMPA coordinates surface mail with SDDC, including drayage to consignees, and enters the sealand container information in AMPS.

(2) MPAs receiving sealand containers will report delivery date in AMPS.

(3) MPAs using sealand containers to transport postal items will secure the doors with a serialized seal. For multi-stop service, the unloading activity at each stop will reseal the container and enter the seal number on the DD Form 1384-E in AMPS.

k. MPAs will use a closed-body vehicle equipped with lockable doors or a sealand container to transport postal items between MPAs or carrier facilities to ensure safety and security of the mail. Postal items will always remain in sight of postal personnel to prevent loss, theft, or introduction of contraband and prohibited materials.

l. Postal personnel will affix a numbered seal to secure the vehicle or container doors. Annotate seal number on the manifest. Receiving activities verify and remove seals. Check seals each evening and again in the morning before departure.

m. Use customs clearance documents for postal items transiting international checkpoints IAW Form 302, Import/Export Customs Declaration.

n. Manifest postal items for commercial air transportation by weight in kilograms rounded to the nearest tenth.

o. Manifest postal items for military air and surface transportation by weight in pounds rounded down to the nearest whole pound if the net weight remainder is eight ounces or less; otherwise, round up to the nearest whole pound.

p. MPSA may authorize manual dispatching if AMPS is unavailable for more than 24 hours. Military Services may request ETPs from MPSA to dispatch manually if AMPS is unavailable and a location is unable to store the volume until the next dispatch opportunity. Dispatching locations may make edits, adjustments, or cancellations directly to a PS Form 2942-A/AV-7 created in AMPS up to eight days from the date of dispatch. After eight days, a PS Form 2734-B must be completed in AMPS to correct or cancel a specified PS Form 2942-A/AV-7.

q. Dispatching MPAs will conduct meetings with local air carrier representatives to discuss irregularities and resolve identified deficiencies as needed.

SECTION 29: TRANSPORTATION

29.1. General.

a. The MPS is responsible for coordinating the transportation of postal items by mail class and services purchased promptly, efficiently, and economically in support of DoD missions.

b. Postal items are transported using the following categories: Expedited, Preferred, Deferred Air, and Deferred Surface.

c. MPSA may request USPS change the mail transportation priority when circumstances require the upgrade or downgrade of deferred mail. The following criteria will exist to change deferred prograde [postal](#) to surface transportation:

(1) The deferred mail volume exceeds the capacity of commercial carriers and AMC transport.

(2) The deferred mail on hand will be equal to at least two-day's generation and forecasted to remain at or exceed that level of generation for an additional seven days or longer.

d. The decision to upgrade deferred mail will be based on the circumstances, carrier capacity at the time along with MPSA and Service recommendations to the specific area.

e. In coordination with CCDRs or Military Services, DoS may authorize Embassy or Consulate locations to use MPS internal transportation assets destined for an MPO on a reimbursable basis. Postal personnel are not allowed to open or inspect closed pouches destined to a DoS location.

f. In the US and its territories, MPS mail is transported over post road by DoD personnel only. (IAW 3-4, Letters of the Carrier (39 CFR 310.3(b)))

29.2. Requirement.

a. Postal items will be transported by commercial air unless unavailable, does not have sufficient frequency, capacity, or cannot meet the required delivery date (RDD).

b. MPSA coordinates with USPS for commercial air transportation to O&D locations. Only commercial air O&D pairs are available in AMPS.

c. Military Services will coordinate with MPSA to add O&D pairs.

d. The Military Services, in coordination with MPSA may authorize the use of military air movement when circumstances require (i.e., to establish support, and/or avoid delays in mail movement).

e. Dispatch retrograde [postal](#) IAW USPS published guidance. Dispatch retrograde [postal](#) to

an ISC that corresponds with the destination ZIP Code of that mail hen transportation does not exist from a dispatching location to an ISC, dispatch to the USPS designated alternate ISC (e.g., no transportation to MIA, dispatch mail to JFK).

f. When an accident or incident occurs while postal items are being transported, the local MPA nearest the scene or a designated representative will:

(1) Coordinate with the appropriate authorities to gain access to the accident scene, assist with the recovery of postal items, and if allowed, return the items to postal channels.

(2) Submit a PNA.

(3) Recover postal items and equipment from the accident scene.

(4) Determine the postal loss or damage to the extent possible.

(5) Re-dispatch undamaged postal items and damaged but deliverable postal items to the intended destination. Ensure undeliverable postal items are handled correctly.

(6) For undeliverable postal items see Section 21, Directory for handling.

(7) Notify patrons, through the daily bulletin or other news media, of the damage or loss of postal items. Provide patrons with instructions for processing claims.

g. MPAs will sanitize receptacles (pouches, tubs, and trays) at the time of receipt by ensuring they are empty of mail, and free of old exterior tags and labels to prevent misrouting future dispatches.

SECTION 30: INTRA/INTER-THEATER DELIVERY SERVICE (IDS)

30.1. General.

- a. IDS items must meet the requirements and restrictions for MPS correspondence. Items will be sent only to MPO addresses and must not transit through USPS channels.
- b. USPS shipping products and extra-services are not authorized for IDS use with the exception of the Customs Declaration.
- c. OPCs may utilize registered/certified labels (at no cost) and chain of custody procedures, and DoD approved OM barcoded labels on official correspondence sent IDS for tracking purposes only.
- d. Patrons assume all liability for lost or damaged correspondence.
- e. IDS shall be dispatched deferred; receptacles shall have a deferred EDL affixed.

30.2. Requirement.

- a. In lieu of postage, the endorsement “IDS” must be visible in the upper right-hand corner, on the front of envelopes and parcels.
- b. MPAs will ensure prompt directory service for undeliverable IDS items. Do not forward IDS items if the addressee has been transferred to the U.S., international, or an MPO which requires the item to transit the USPS system. IDS items that cannot be forwarded or returned will be sent to the designated IDS Recovery Office for disposition. Do not send undeliverable IDS to a USPS MRC.
- c. COCOM may publish detailed IDS policies and procedures. However, policies and procedures cannot be more permissive than DoD level guidance and must be coordinated with MPSA.
- d. All IDS correspondence and parcels must meet all requirements for mail, other than postage, including complete delivery and return addresses. Always include the grade, full name, unit name, CPR/PSC/unit number, lock-box number (if applicable), and ZIP Code. Commercial and private organizations must use their organizational return address.
- e. Any envelope or container acceptable as U.S. mail is also acceptable for IDS. Envelopes and containers will be sealed. The use of USPS trademark packaging materials are prohibited for IDS mailing.
- f. Mail markings (those designating rate, class, handling, content, or extra-services) are not permitted. Any previous marking on an envelope/container to be reused must be completely obliterated. Paper, tape, or heavy marking pen must be used to completely cover all previous markings.

g. The following conditions and restriction apply with the use of IDS:

(1) Sending or receiving items through the IDS to advertise home businesses, to sell merchandise, or to conduct business or for commercial purposes is prohibited. This resale prohibition applies whether sale is to an authorized MPS user or not, and regardless of the beneficiary of the proceeds, i.e., charitable organizations or non-appropriated welfare fund activities.

(2) To prevent overburdening the MPS system, flyers, notices, announcements, advertisements, etc., for on-base personnel and activities will not be sent IDS or be deposited in delivery receptacles.

(3) Commercial advertisements will not be sent by IDS except for commercial advertising enclosed with operational announcements, bills or bank statements.

(4) Use of IDS for transport of personal property in connection with Permanent Change of Station (PCS)/TDY moves, is prohibited, with the exception of uniforms and military gear required to perform official duties at next duty station. Such use of the IDS requires coordination with the transportation office to ensure weights being shipped comply with official orders.

h. Any postal items that are prohibited from being mailed are also prohibited from being accepted in the IDS. This includes matter that is illegal (drugs, pornography, weapons), as well as hazardous materials.

i. Suspected violations of IDS restrictions shall be reported to the Postal Officer or MPO Supervisor.

SECTION 31: POSTAL NET ALERTS (PNA)

31.1. General. PNAs are used to notify MPAs of issues affecting the USPS or MPS networks, which may delay DoD postal items.

31.2. Requirement.

a. Generate a PNA in AMPS for man-made or natural disasters that results in any of the following:

(1) Infrastructure closure, damage or destruction.

(2) Air, ground, and surface carrier backlogs or operations causing cancellation or delay which may impact down line operations.

(3) Airline or postal strikes.

b. Submit PNAs within one workday of occurrence. MPAs will provide updates as changes occur but no more than 10 days until final disposition.

SECTION 32: IRREGULARITIES

32.1. General. The irregularity report is used to identify USPS, MPS or commercial air carrier oversights.

32.2. Requirement.

a. MPAs provide a concise statement of the issue, actions taken to correct, and recommendations to preclude reoccurrence. Report within 24 hours: Registered irregularities, missed transfers, tagging and labeling irregularities and damaged mail to enroute destination and origin activities. Refer to instructions available in AMPS, Knowledge Management.

b. MPAs will prepare the following forms in AMPS:

- (1) PS Form 3826 for registry irregularities.
- (2) DD Form 2273 for irregularities in the makeup and dispatch of mail.
- (3) PS Form 2759-M to document the irregular handling of mail.

SECTION 33: INQUIRIES

33.1. General.

- a. Patron inquiries on mail should be validated with USPS website “Find Missing Mail” to verify status.
- b. Congressional Inquiries (CI) on mail or MPS operations have a specific suspense date and are coordinated with MPSA or Military Services.
- c. Inquiries are assigned to the SCC.

33.2. Requirement.

- a. Provide response to inquiries within two business days.
- b. Provide responses to CI within requested suspense date.

SECTION 34: CLAIMS

34.1. General.

- a. Patrons may file mail claims for loss or damage via the USPS website: <https://www.usps.com/help/claims.htm>.
- b. Claims filing timelines are located in the USPS DMM, Section 609.
- c. Insurance claims cannot be filed for IDS items.

34.2. Requirement.

- a. Damaged items presented to the MPO will be handled IAW USPS DMM, Section 609 and USPS POM, Section 147.
- b. Domestic indemnity claims should be filed online. USPS will provide written instructions to the customer and the local Post Office regarding inspection, retention, and disposition in accordance with the decision made by USPS claims.

SECTION 35: POSTAL REPORTS

35.1. General. Report postal incidents and losses in AMPS Postal Reports.

35.2. Requirement.

a. Postal Officer, MPO Supervisor and OPM will determine who will be notified depending on the category of issue.

b. Upon discovery of a suspected offense against the MPS, MPAs will submit an initial report within 72 hours in AMPS.

c. SCCs will:

(1) Update Postal Reports every 30 days until final disposition.

(2) Close Postal Report based on the adjudication.

d. The following actions will be taken involving postal personnel:

(1) Temporarily remove the individual from the MPA.

(2) Recommend for possible non-judicial punishment or civil/administrative action.

(a) Punitive:

1. Terminate the postal duties and responsibilities of the employee on their respective Designation Letter of Appointment.

2. Request revocation of Military Occupational Specialty/postal identifier.

3. Request the personnel office to flag records to prevent actions, reassignment, and promotions. Ensure personnel records are annotated to preclude future postal assignments.

(b) Non-punitive. Official counseling regarding incident.

(3) Review MPO records for claims actions involving accountable mail.

(4) Advise sender or addressee of mail loss.

SECTION 36: INSPECTIONS

36.1. General.

a. USPS Pub 38, Section 8 and DoDI 4525.09, Section 2.2.j. provide guidance on inspections. Inspections ensure compliance with postal requirements; provide a method for assessing and adjusting policy, procedures, and training; and facilitate sharing of best business practices across the MPS.

b. Inspections performed by the USPS, MPSA, DoD and Service Audit Agencies, Service Inspector Generals, or Service postal staffs meet the annual inspection requirement.

c. MPA inspections will occur at least annually to determine if they are performing their mission in an effective and efficient manner per established laws, regulations, and USPS/DoD regulatory documents.

d. Inspections will measure the activities responsiveness to problem areas and corrective action taken on previously noted irregularities and deficiencies.

e. MPSA may conduct site visits or inspections IAW DoDD 5101.11E., Section 3.2.k.(1).

f. USPS personnel may inspect MPAs after coordination via MPSA, who shall coordinate with the Military Services.

g. Designated representatives of the servicing MPA reserve the right to conduct unannounced inspections of all DoD and non-USPS operated CPRs, PSCs and UPRs they service.

h. AMPS provides commanders a minimum reportable requirement inspection checklist to assist MPS and OM managers in developing a viable inspection program.

36.2. Requirement.

a. MPAs will be inspected within 365 days. Should a MPA fail an inspection the MPA will require a corrective action. A follow-up inspection will be scheduled prior to the next annual inspection.

b. SCCs shall maintain all inspection records within their purview IAW DoD and USPS records management policy. SCCs will forward copies of inspection reports to MPSA-OP, IAW DoDI 4525.09, Section 2.2.j.

c. Inspections conducted IAW USPS Publication 38 and DoDI 4525.09, using a checklist derived from Appendix 36A [this manual] will meet the annual requirement.

d. Inspection results will be uploaded into AMPS NLT seven days after signature of the certifying authority.

APPENDIX 36A: MILITARY POSTAL ACTIVITY INSPECTION CHECKLIST

	MPSA	JMPA	DOD Agencies	CCDR	Military Services	SCC	MMT/MCA	MPO	OPC	PSC/CPR/UPR	IEO MRC	Reference
ADMIN/PERSONNEL												
MPA coordinates with MPSA prior to negotiating with USPS representatives to change existing support on US installations?	X		X		X			X	X	X		DoDI 4525.09, 2.2.m.
MPA profile in AMPS is current?			X	X	X	X	X	X	X	X	X	MPM S2.12.t.
MPA inspected annually?			X			X	X	X	X	X	X	MPM S2.3.b., 2.9.j., 36.1.c., and 36.2.a.
Were all previous inspection findings/discrepancies corrected within applicable timeframe?			X			X	X	X	X	X	X	MPM S36.2.a.
MPA screens postal items addressing risk assessment and handles suspicious items appropriately?			X				X	X	X	X	X	MPM S5A.3.a.(4)(b), 5A.3.c.(3)(l), 7.2.a., and 8.2.j.
MPA maintains documents designating postal personnel?			X			X	X	X	X	X	X	MPM S5A.4.a.(1)(a) and 5A.4.b.(10)
MPA personnel are trained on duties performed?			X			X	X	X	X	X	X	MPM S5A.1.b.(2)
MPA personnel receive annual records checks for derogatory information which could affect continued employability?	X	X	X	X	X	X	X	X	X	X	X	MPM S35.2.d.(2)(a)3.
MPA reports personnel removed for cause from postal duties within one workday with revocation of AMPS account?			X		X	X	X	X	X	X	X	MPM S35.2.d.
MPA personnel handling "Registered" OM that may contain classified material have at least an interim Secret clearance?			X				X	X	X	X		MPM S12.2.e., 23.1.b.
MPA have a COOP in place and reviewed annually?	X	X	X			X	X	X	X	X	X	MPM S2.9.g. and 15D.2.b.
MPA screens and consolidates DoD OM prior to applying postage?			X					X	X			MPM S41.2.m., 41.2.q., and 41.2.r.
MPA Security Plan includes procedures for receiving incoming and sending outgoing OM to an alternative worksites, or telework locations.			X					X	X			MPM S41.1.h., and 41.2.y.
MPA personnel user accounts with IDs and passwords are properly protected from unauthorized use or other use by other personnel?	X	X	X	X	X	X	X	X	X	X	X	MPM S38.2.b.
MPA submits seizure report within one workday of confiscation?			X	X	X	X	X	X	X	X	X	MPM S7.2.p.
MPA provides support to authorized patrons only?			X					X	X	X		DoDI 4525.09.3.6.a. and MPM S9.1.d.
MPA ensures FM privileges are managed correctly?	X			X	X				X			DoDI 4525.09.3.12. and MPM S37.
MPAs must properly submit postal reports as required?			X				X	X	X	X	X	MPM S35.
MPA ensures organizations authorized MPS support reimburse DoD costs, such as SDT, as required?				X	X	X		X	X	X		MPM S1.e., 10.1., and 38.2.c.
MPA minimizes overnight and 2-day service for OM?			X		X				X			MPM S41.1.c.(1)
FACILITY												
MPA structure, space, and flow allows for safe working conditions and efficient processing?			X				X	X	X	X	X	MPM S15.2.b. and Appendix 15E.
MPA maintains facility and equipment upgrade plan IAW MPM?			X	X	X	X	X	X	X	X	X	MPM Appendix 15C.
MPA displays required posters and signage?			X				X	X	X	X	X	MPM S38.1.a. and Appendix 38A.
MPA meets physical security requirements?			X				X	X	X	X	X	MPM S8.
MPA maintains COOP IAW MPM?	X	X	X	X	X	X	X	X	X	X	X	MPM Appendix 15D.

APPENDIX 36A: MILITARY POSTAL ACTIVITY INSPECTION CHECKLIST

	MPSA	JMPA	DoD Agencies	CCDR	Military Services	SCC	MMT/MCA	MPO	OPC	PSC/CPR/UPR	IEO MRC	Reference
PROCESSING AND DELIVERY												
MPA processes Priority Mail Express Military Service, Priority and First Class, and Extra-Services mail within 24 hours?			X				X	X	X	X		MPM S19.2.a.(1)
MPA use proper stop the clock PTR event code scanning for expedited items?			X				X	X	X	X		MPM S26.
MPA processes deferred postal items within 3 workdays?			X				X	X	X	X		MPM S19.2.a.(2)
MPA receives and dispatches postal items at least 5 days a week?			X					X	X			DoDI 4525.09, 3.4.d.(4), and MPM S1.m.
MPA receives and dispatches postal items at least 7 days a week?							X					DoDI 4525.09, 3.4.d.(4), and MPM S1.m.
MPA ensures installation has one OM metering site?	X		X	X	X	X		X	X			DoDI 4525.09, 3.1.
MPA properly uses appropriated funds for postage?			X						X			MPM S41.1.a.
MPA transmit scanned barcoded postal item daily?							X	X	X	X	X	MPM S26.2.e.
MPA ensures domestic installation has USPS approved delivery points and USPS delivers?	X		X		X				X	X		MPM S14.1.b
MPA verifies patron or postal clerk identity prior to acceptance or delivery?			X					X	X	X		MPM S1.k., 1.1., 41.2.n., and 41.2.o.
MPA completing the DD Form 2261 daily?			X				X	X	X			MPM S23.2.h., 26.2.e.
MPA registered OM overseas is secured, segregated, and has an alarm system or 24-hour onsite guard?							X	X	X	X		MPM S8.2.b.
MPA receptacles checked monthly for aged mail?			X					X	X	X		MPM S18.2.m.
MPA ballots and election materials receive special handling and expedited movement?	X	X		X	X	X	X	X	X	X	X	MPM S19.2.a.(1)
MPA developed a SOP for mail handling?			X	X	X	X	X	X	X	X	X	MPM S2.12.n. and 2.13.f.
MPA has written procedures in place to limit increased costs, mitigate security vulnerabilities, and maintain accountability, of OM sent to an alternative worksite or telework location.			X					X	X			MPM S41.1.h.
MPA monitors and responds to inquiries and postal reports as required?							X	X	X	X		MPM S33.2. and 35.2.
FINANCE												
MPA conducts audits of financial accounts IAW F-101 Chap 2-4.3?								X				MPM S5A.4.a.(1)(d), 5A.4.b.(4), 25.1.a., and 25.1.e.
MPA maintains records for financial accounts IAW F-101 Appx D?								X				MPM S2.13.d., 2.14.c., 25.2.m., and 38.1.c.
MPA trusts, expenses, overages, and shortages are resolved within 30 days?								X				MPM S25.1.e.
Does the responsible commander authorize, in writing, window clerks to retain fixed credits in excess of \$1,000?								X				MPM S24.2.k.(1)
MPA reports suspicious money order transactions on PS Form 8105- B?								X				MPM S24.2.c.(1)
MPA makes deposits as required?								X				MPM S24.1.e.
MPA payment card industry terminal inspections completed as required?								X				MPM S2.14.i. and 24.2.h.

APPENDIX 36A: MILITARY POSTAL ACTIVITY INSPECTION CHECKLIST

	MPSA	JMPA	DoD Agencies	CCDR	Military Services	SCC	MMT/MCA	MPO	OPC	PSC/CPR/UPR	IEO MRC	Reference
EQUIPMENT AND SUPPLY												
MPA evaluated need for postage evidencing equipment and minimized costs?			X		X		X		X			MPM S41.1.f.
MPA accounts for USPS and DoD purchased, leased or contracted postal equipment in AMPS?		X	X		X	X	X	X	X	X	X	MPM S2.3. and 2.8.d.
MPA inventories equipment on PS Form 1590 annually and during inspections?		X	X			X	X	X	X	X	X	MPM S2.3.d.
MPA maintains supply stock levels in AMPS?							X	X	X	X	X	MPM S16.
TRANSPORTATION												
MPA mail is transported over post road by DoD personnel in the US?			X		X			X	X	X		MPM S29.1.f.
MPA nests barcoded postal items by transportation category?							X	X				MPM S27.2.a.
MPA uses customs clearance documents for postal items transiting international boundaries?							X	X				MPM S28.2.m.
MPA affix EDLs for correct Service and transportation category?							X	X				MPM S27.1.b.(3)
MPA affixes Label 150 (Universal Postal Union label) to the receptacle or OSP?							X	X				MPM S28.2.d.(2)
MPA assigns postal items to air carriers IAW ICAIR rankings unless otherwise approved by MPSA?							X	X				MPM S28.2.a.
MPA verifies a DoD employee closes the dispatch, finalizing the AV-7?							X	X				DoDI 4525.09, Para 3.3.c.(2), MPM S28, and Office of Federal Procurement Policy Letter 11-01
MPA manifests postal items on DD Forms 1372-E or 1384-E?							X	X				MPM S28.2.e. and 28.2.g.
MPA transports postal items in authorized vehicles?			X				X	X	X	X	X	MPM S28.2.k.
MPA uses PS Form 2734-B for adjustments over 8 days from the date of dispatch?							X	X				MPM S28.2.p.
MPA completes PNAs as required?		X	X	X	X	X	X	X	X	X	X	MPM S31.
MPA submits PS Form 2759-M within 24 hours of occurrence?						X	X	X				MPM S32.2.a.
MPA dispatches IDS as deferred?							X	X				MPM S30.1.e.
* NOTE: If item is not applicable mark Not Applicable (N/A)												

SECTION 37: FREE MAIL (FM)

37.1. General.

- a. DoDI 4525.09 provides policy and Joint Publication 1-0 provides operational planning.
- b. CCDR submits FM requests, MPSA reviews and makes a recommendation to USD(A&S).
- c. The USD(A&S) coordinates with the DoD General Counsel to confirm that the request complies with the law.
- d. The SECDEF will notify the USPS Postmaster General of approved FM locations.
- e. USD(A&S) will send decision memo to MPSA who will notify the JS and CCDR of the FM approval or disapproval.
- f. FM is limited to First-class letter mail having the character of personal correspondence (such as a letter, or postcard) sent from an MPO to a domestic address.
- g. FM will not be introduced into the international mail system.
- h. FM will not be used for OM.
- i. In coordination with CCDRs via the JS, MPSA will conduct periodic reviews of FM areas to ensure the designated areas meet requirements and provide the USD(A&S) policy the results of the review.

37.2. Requirement.

- a. The criteria for establishing FM in a country necessitates three items before submitting the request through MPSA to USD(A&S):
 - (1) A HNA allowing military mail, the US is conducting forced entry operations into that country, or the CCDR has an approved ETP to DoDD 5101.11E, Section 2.7.c. and DoDI 4525.09, Section 2.5.b. from OSD to provide postal support.
 - (2) An MPO must be identified to provide service prior to FM being authorized.
 - (3) Infrastructure support (transportation, personnel, etc.) must exist for the above MPO.
- b. The CCDR submits a FM request with justification to OSD through MPSA and the JS.
- c. CCDRs conduct regular reviews and terminate FM earlier than one year or request an ETP if location has been unable to establish MPO services.

SECTION 38: INFORMATION MANAGEMENT

38.1. General.

- a. MPAs must have access to required publications, posters and forms. Refer to Appendix 38A (this manual) for specific guidance to locate or obtain publications, posters and forms.
- b. AMPS Knowledge Management lists the required publications and posters. Posters may be ordered through AMPS.
- c. Retain postal financial and administrative records IAW USPS and DoD records management. Refer to Appendix 38A (this manual) for specific record retention instructions.
- d. Forms and records generated and achieved in AMPS, eliminate the requirement for MPAs to maintain a hard copy.

38.2. Requirement.

- a. MPAs must have access to USPS, DoD, and GSA publications governing postal. MPAs will display required posters. See AMPS Knowledge Management (Notices and Posters).
- b. Postal personnel will prevent others from accessing user AMPS and RSS accounts with IDs and passwords.
- c. Reporting Requirements for Automated Accounting System and Mail Movement Reimbursements. The following data collection systems are used by MPSA for measuring and monitoring volume and associated costs for reimbursement of mail movement:
 - (1) Provides segment volumes and associated transportation costs for mail moved by U.S. or foreign commercial air carriers, SDDC, and AMC.
 - (2) Mail Movement Reimbursement System for non-DoD agencies. This data is designed to calculate the non-DoD cost for MPS usage. Non-DoD agencies are billed annually with appropriate disbursements made to each of the Military Departments.

APPENDIX 38A: POSTAL FORMS PROCUREMENT AND RETENTION

Records serve a vital role in documenting the business of the MPS providing visible accountability of the operations function, policy, and procedures to the public, congress, and the Department of Defense. Records support effective claims, inquiries, custody accountability, and decision-making thus enhancing readiness; as well as protecting the legal rights of the DoD and the patrons supported by the MPS

<i>Where do I get the most current forms??</i>			
Agency Form	Source	Procurement	Website/URL
USPS (PS)	Online/AMPS - Knowledge Mgmt./AMPS (supply) Order	Print Onsite/ FEDSTRIP	https://about.usps.com/resources/forms.htm
DoD (DD)	Online/AMPS - Knowledge Mgmt./local Publications Office	Print Onsite/Unit Request	https://www.esd.whs.mil/Directives/forms/
Standard Form (SF) Optional Form (OF)	Online/AMPS – Knowledge Mgmt./local Publications Office	Print Onsite/Unit Request	https://www.gsa.gov/reference/forms

*Note: Military Service specific forms are available via online sources or through the installation Forms and Publications Manager.

<i>Which forms do I keep?? And how long do I keep them??</i>		
Agency Form	Source	Reference Document
USPS (PS)	USPS	Administrative Support Manual (ASM), Issue 13, published in July 1999 is updated through November 2023
DoD (DD) Standard Form (SF) Optional Form (OF)	DoD Records and Information Management Program	OSD Records Disposition Schedules (https://www.esd.whs.mil/RIM/)

* NOTE: Refer to the Records and Information Management (RIMS) Programs of the respective Service for retention instructions associated with Service specific forms.

** NOTE: DoD forms are covered under the General Schedule on the DoD Website. Basic standard for Government Official Records retention in 2-yrs. (minimum).

*** NOTE: Forms associated with an investigation are retained for 2-yrs., or 2-yrs. from conclusion of the investigation, unless otherwise specified.

SECTION 39: ABSENTEE BALLOTS AND ELECTION MATERIALS

39.1. General.

a. The Federal Voting Assistance Program (FVAP), the Military and Overseas Voter Empowerment Act, the Uniformed and Overseas Citizen Absentee Voting Act, and MPSA Strategic Postal Voting Action Plan provide guidance for processing absentee ballots and election materials.

b. Overseas MPAs process absentee ballots and election materials in the most expeditious manner.

39.2. Requirement.

a. Service postal representatives will ensure assigned Postal Voting Representatives (PVR) complete the AMPS Voting Training and Certification exam per MPSA voting action plan and each MPA designates and assigns two or more PVRs.

b. MPAs:

(1) Must inventory voting supplies and equipment on hand and enter the required data into AMPS voting module. Service PVRs will ensure units have the required supplies and equipment.

(2) Must provide directory service immediately to undeliverable absentee ballots and materials.

(3) Will apply the PMEMS Label 11-DoD to only authorized voted absentee ballots for US General and Presidential Elections, including Federal Write-in Absentee Ballots dispatched from overseas MPAs (including Coast Guard vessels).

(4) Must perform a product tracking "acceptance" scan event code for the PMEMS Label 11-DoD on the date of mailing by:

(a) Scanning, uploading, or manually entering in the AMPS Voted Ballot module.

(b) Scanning or manually entering data via the retail system.

(c) Applying "acceptance" scan during the nesting process.

(5) Collecting absentee ballots must provide a clear legible postmark or All-Purpose Date Stamp on the date of acceptance for the voted ballot.

(6) Must use the AMPS voting training guide to prepare USPS receptacles for the transportation of ballots and material.

c. PVRs:

(1) Enter prograde absentee ballot counts for “Received,” “Redirected,” and “Returned to Sender” in the AMPS voting module. SCC PVRs will monitor and resolve delays.

(2) Report ballot disposition via AMPS.

(3) Generate a PNA in AMPS for delays and disruption impacting absentee ballots during General and Presidential elections. SCC PVRs will monitor and resolve delays.

SECTION 40: BILLING

40.1. General.

- a. USPS pays carriers to transport DoD postal items. DoD reimburses USPS for costs IAW USPS Pub 38 and 39 U.S.C. 3401.
- b. MPSA validates invoices and ensures reimbursement by the Military Services for commercial and military air and surface transportation of mail.

40.2. Requirement.

- a. Military Services are responsible for:
 - (1) Postal transportation second destination costs incurred using USPS ICAIR and non-USPS contracted transportation.
 - (2) Postal transportation costs incurred using AMC (MILAIR) and SDDC (sealand containers).
 - (3) Providing USPS reimbursement for Free Mail postage and transportation cost for OSD approved locations.
- b. Military Services will:
 - (1) Designate in writing the personnel authorized to approve quoted transportation rates for service specific routes. Designating authorities will ensure all personnel so designated; have signed a non-disclosure agreement associated with proprietary route/rates information.
 - (2) Use an electronic payment system for reimbursements to the USPS.
 - (3) Submit payment within 30 days of the invoice date.
- c. MPSA will:
 - (1) Provide the Military Services' Representatives with the status of USPS acknowledgement, validation and receipt of payment on a weekly basis.
 - (2) Notify OSD regarding payment in excess of 30 days.

SECTION 41: DoD BUSINESS/OFFICIAL MAIL

41.1. General.

- a. Authorized use of appropriated fund postage:
 - (1) To pay the postage for OM relating solely to the business of the United States

Government.

(2) By the National Guard when mobilized for federal service under either Title 10 (U.S.C.) limited to mailings pertaining to Federal Government matters.

(3) By an activity or activity commander for inviting non-DoD dignitaries to attend official functions held on behalf of a DoD Component or sponsored in the name of a DoD Component. The official status of the function shall be clearly stated or readily apparent in the invitation. For example, an installation commander is authorized to use appropriated fund postage to invite community officials to an installation open house, change of command or town hall.

(4) Official announcements of official retirement, promotion, award, change-of-command, and ship commissioning or decommissioning ceremonies. The location and time of a directly related reception may be noted if it does not result in any increase in cost to the government, and the notation does not include advertisement for or endorsement of any enterprise.

(5) Heads of staff agencies or commanders to fulfill their official morale and esprit de corps obligations to members of their organization or persons in their areas of technical responsibility. For example, sending congratulatory letters to people selected for advanced schooling, promotions, and letters of condolence are authorized.

(6) For mailing change-of-address cards only for changes of address resulting from carrying out written military orders. A copy of the orders must be presented to the **OPC** with the cards.

(7) For mailing bulk shipments of daily, weekly, housing and similar bulletins to supported installations and activities only. Less costly methods of shipment must be considered and used when feasible.

(8) Contractors when authorized by the terms of their contract will receive OM support on a reimbursable basis, unless otherwise stated in DoD contracts, and/or the members Letter of Authorization.

(9) May be used to mail a consolidated packet containing information regarding the existence of all available Morale, Welfare and Recreation activities to personnel eligible to use them; however, the packet shall neither contain information on revenue producing items or events nor violate other parts of this Manual. A revenue producing item or event is one where the recipient or participant pays for all or part of the cost of the service or goods received. The category of the organization providing the goods or service is immaterial.

(10) By prisoners in a non-pay status for personal mail as described in DoDI 1325.07, Encl 2, paragraph 8.e.(8).

(11) Items associated with tax filing programs established by DoD Components under

Title 10 U.S.C. Section 1044.

(12) Information may be included in official command publications such as daily, weekly, housing, and family support group-type bulletins/newsletters when the local commander determines its dissemination will contribute to morale or esprit de corps. Such information may be included only if it is not otherwise prohibited by this manual, it does not exceed 20 percent of the printed space used for the official information, and it does not include personal wanted/for sale advertisements.

(13) For FM under 39 USC 3401 and DODI 4525.09, Section 3.

b. Unauthorized use of appropriated fund postage may be charged under 18 U.S. Code 641:

(1) Non-appropriated Fund Instrumentalities (NAFI) or their functions. Unless specifically otherwise authorized by the local commander, the NAFI must reimburse OM cost.

(2) Invitations to social functions to satisfy personal social obligations, even if they are the result of an official position. For example, Christmas parties, and receptions hosted by senior commanders are not official business.

(3) Personal congratulatory letters from one individual to another in a private capacity.

(4) Personal mail such as holiday and birthday greetings, unofficial retirement announcements, PCS or retirement plaques, and other similar material.

(5) Correspondence from international commands.

(6) Correspondence of foreign military personnel.

(7) Dependent school year books, Navy Cruise Books, and other unofficial items such as announcement cards, thank you cards, memory albums, and biographies.

(8) Announcements and attendance responses related to DoD Component branch anniversary parties and similar events.

(9) Mailings by or for private associations, such as unit associations, spouses' clubs, Boy Scouts, Association of the United States Army, and the Air Force Association.

(10) Social events related to the reassignment or resignation of individuals not in command positions.

(11) RSVP items. The rate of return on these items is too low to justify the expense of pre-paying the postage on each item.

c. Extra Services:

(1) Limit the use of extra services to when required by law or DoD Regulation. Upon written request to local installation/agencies OPM are authorized to approve the use of these services on an exception basis.

(2) Claims shall not be made against the USPS for indemnity on items lost or damaged in the mail.

(3) Registered Service:

(a) Criminal investigation evidence.

(b) Cash, original vouchers (disbursing and collecting), and voided or canceled checks.

(c) Mailable shipments of Government-owned firearms.

(d) Classified material required by DoD 5200.01 Vol 3.

(4) Proof of Delivery: PS Form 3811 or electronic return receipt may be used only on PMEMS, registered and certified mail.

d. OM is exempt from customs documentation; except for those APO, FPO, and DPO locations to which restriction B2 applies as required in the Overseas Military/Diplomatic Mail section of the USPS Postal Bulletin.

e. For expedited services, OPMs must use the Next Generation Delivery Service (NGDS) commercial carrier contract to move items while complying with the PES. The use of expedited services should be kept to a minimum.

f. Deactivation, activation, or corrections for address management will be coordinated with local postmaster.

g. Ensure postage evidencing system is appropriate and minimizes cost.

h. OM may be sent to home addresses of teleworking employees providing the responsible OPC has written procedures in place to limit increased costs, mitigate security vulnerabilities, and maintain accountability.

i. DoD OPM ensures all DoD OM expenditures are accurately captured by each of the respective DoD Component and submits report to GSA via the Simplified Mail Accountability Reporting Tool (SMART) annually, NLT Dec 1st.

j. Installation tenant/unit operations and activities (non-OM related) will not be co-located within the secure postal processing area of an OPC facility. OPCs shall maintain restricted access, postal personnel not properly designated/appointed to perform OM duties shall be signed in and escorted when visiting an OPC.

k. Drop shipments are not authorized at the Official Postal Centers. Bulk shipments such as supplies, parts, and equipment will be refused and redirected to the local Logistics Readiness Center or Traffic Management Office. Official Postal Centers are designed to exclusively handle official correspondences that is 70 pounds or less and has an official mail address.

41.2. Requirement.

a. OPMs at all levels are appointed in writing by the commander responsible for Postal.

b. Appoint OM personnel in writing according to the following:

(1) Official Postal Managers, GS-13 and above or military equivalent to manage the Service Component OMP.

(2) Official Postal Managers, GS-11 and above or military equivalent to manage multiple Installations OMP.

(3) Official Postal Managers, GS-9 or military equivalent to manage the Installation OMP.

c. Official Postal Manager designation letter will be maintained by the authorizing organization and supporting MPA.

d. Military Component/US Defense Agency OPMs:

(Pursuant to operations under assigned purview of responsibility)

(1) Ensure each OPCs/OPMs location input expenses and update quarterly expenditure report NLT 5 business days after the close of each quarter.

(2) Review quarterly updates to the Official Mail Expenditure Reports in AMPS, within 10 business days after the close of each quarter.

(3) Verify and review annual OMP inspections of assigned activities submitted in AMPS.

e. SCC/Regional OPMs:

(Pursuant to operations under assigned purview of responsibility)

(1) Verify OPMs for all assigned OPC activities provide quarterly updates to the Official Mail Expenditure Reports in AMPS.

(2) Conduct annual OMP inspections of assigned OPC activities and submit reports via AMPS.

(3) Review the OPC Facility and Equipment Upgrade/Improvement Plan and Continuity

of Operations Plan (COOP) for assigned activities.

f. Installation/OPC OPMs:

(Pursuant to operations under assigned purview of responsibility)

- (1) Provide quarterly updates to the Official Mail Expenditure Reports in AMPS.
 - (2) Ensure all NGDS account numbers are annotated on annual Official Mail Expenditure Report submission.
 - (3) Maintain assigned organization/tenant commands address information in AMPS.
 - (4) Account for all serialized OM equipment assigned on the “Inventory List” of the Official Mail Tab in AMPS.
 - (5) Ensure MPA clerks performing OM duties complete required training in AMPS.
 - (6) Maintain a current OPC Facility and Equipment Upgrade/Improvement Plan and Continuity of Operations Plan (COOP) on hand.
 - (7) Ensure cost saving measures are employed in accordance with USPS, GSA and DoD regulations and policies.
 - (8) Manage OM operations and personnel assigned to the OPC.
 - (9) Installation or equivalent OPMs shall inspect annually all staff, subordinate, and tenant activities on a calendar year basis. These inspection reports shall be completed and filed in AMPS and made available for review during MACOM and IG DoD inspection Staff Assistance Visits.
- g. Consolidated OM containers should be opened in the OPC for further distribution. Units may not open OM in the OPC.
- h. Personnel, to include mail orderlies, will have at a minimum a favorable background check completed prior to appointment or part of the hiring process. Personnel handling registered or certified OM, first class mail, or small parcel shipments in the United States, will have an interim or fully adjudicated SECRET clearance. Personnel handling registered OM outside the United States, will have an interim or fully adjudicated SECRET clearance. Once the item is identified as SECRET, personnel will handle the item IAW DoD Manual 5200.01 Vol 3. At no time are non-US citizen staff authorized to accept, handle, or deliver official U.S. registered mail. Personnel with access to the Registered mail cage or supervise OM must have a SECRET clearance.
- i. Temporary hires will not handle accountable mail, or open mail; and must work under physical supervision of postal personnel at all times.

- j. OPM shall establish and carry out a program to train all personnel involved with the handling of OM duties, to include units, agencies and contracted personnel.
- k. Use automated tracking systems to control accountable mail and commercial carrier items.
- l. Deliver mail addressed to “Commander of” an individual, duty title, office symbol as OM.
- m. OPCs shall provide OPC operating hours, distribution, and delivery schedules and outgoing mail close out times to tenant units and patrons.
- n. When personnel pick up postal from servicing MPAs, check the Designation Letter of Appointment on file and members ID to verify eligibility to handle and receive individual categories of postal items (i.e., All, Personal, Official, Official (except Registered), Personal (except Accountable)).
 - o. Deliver official accountable mail using the PS Form 3883 or other electronic means.
 - p. Prepare items so they qualify for postage discounts when economically feasible.
 - q. Classified items shall be shipped as required by DoD 5200.01 Volume 3, Enclosure 4.
 - r. USPS Permit Imprints are available for bulk mailings. Contact the local Business Mail Entry Unit (BMEU).
 - s. Endorse all Official Mail (OM) and Official Correspondence (OC) with “OFFICIAL BUSINESS” below the return address for customs and security reasons.
 - t. Use Intra/Inter-Theater Delivery Service endorsement “IDS” for OM.
 - u. Limit use of expedited services. Official correspondence must be mailed at the lowest postage and fees cost to meet the RDD, security, accountability, and PES requirements.
 - v. USPS extra-services require payment of postage. Consolidating mail pieces into a flat rate box or small parcel express carrier to avoid use of postage violates the PES and voids use of the extra-service.
 - w. OPCs will NOT permit OM items to be sent when the sender and receiver are the same individual.
 - x. Limit mailing documents when alternate means exists. (i.e., email or shared portals)
 - y. Use AMS compliant addresses only. DoD-provided addresses and address lists shall be matched against appropriate USPS AMS files using Coding Accuracy Support System software. Addresses that do not match shall be corrected or removed prior to delivering the address or list to the requestor. USPS Account representatives and Postal Business Service Centers can provide

more information on how to have addresses and lists matched.

z. Official postal items presented for mailing must have a “from” and “to” address and should be a printed label or typed. Only in extreme circumstances (austere environment) such as no connectivity, lack of printing equipment, or actively participating in a field environment may addresses be legibly hand printed. All official items must be endorsed with the words “Official Business.” See examples below.

Example of “From” address:

DEPARTMENT OF THE ARMY
Commanding Officer
ATTN: Supply Officer 30th Engineer Bn.
1234 Main Street
Fort Jones, VA xxxxx-xxxxx

Example of “To” address:

Mr. J. Doe
4321 Motivation Blvd.
San Diego, CA xxxxx-xxxxx

OFFICIAL BUSINESS

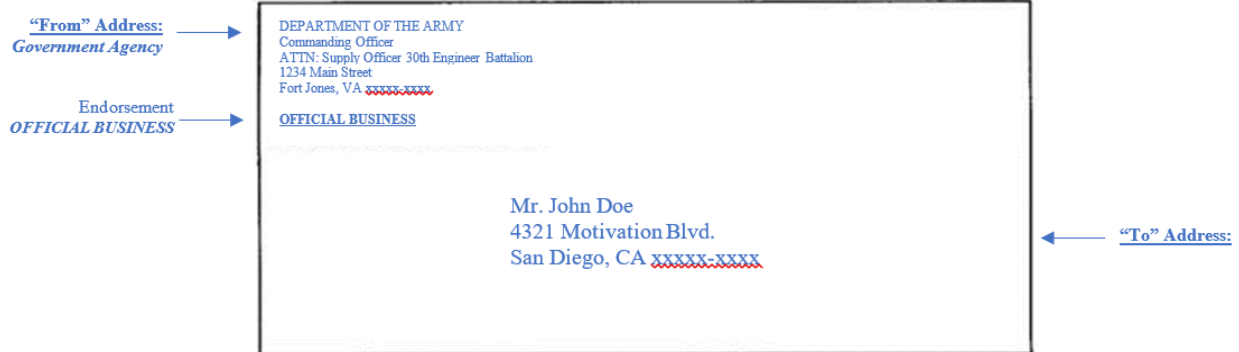

aa. OPC’s must screen all incoming and outgoing OM, prior to sending it to an alternative worksite, telework location. All OM must transit an origin, and destination OPC prior to arriving an alternate, telework, or remote-work location.

bb. Assignment of new or additional ZIP Code Plus 4 shall be requested from the local USPS AMS Office via the Installation OPM.

cc. The Installation OPM must coordinate activation/deactivation or relocation of OPC operations with vendors. OPC information will be submitted in AMPS within five business days:

(1) New OPC operations for DoD shall be coordinated with local OPM and MPSA.

(2) For deactivations and closures ensure internal mail drops are empty. Move furniture to ensure mail has not fallen between them and the wall.

(3) The Installation OPM must coordinate with USPS Account Representative or BMEU Supervisor for Business Reply and Bulk Mailing Accounts.

(4) OPM will coordinate with the comptroller for reimbursement of unused OM funds.

(5) USPS equipment and supplies shall be returned to SCC.

dd. Submit the annual (fiscal year) DoD Expenditure/Piece Report for OM costs in AMPS NLT 15 November. IAW DoDI 4525.09, the report will include official mail costs of any mailable matter, and any other mail related costs including those in non-postal contracts. Other examples may include: reimbursement of authorized postage/fees relating to the return of government official equipment or materials to the assigned organization of a remote-working employee; claims reimbursement for authorized official mailing expenses by an employee in TDA/TDY status; or payments for official mail postage made by an organization using the Government Purchase Card, Military Interdepartmental Purchase Request (MIPR), etc.

ee. Report the postage metering and contracted equipment in AMPS OM Postage Meter and Online Inventory. Ensure non-postal contracts costs associated with postal processing and transportation are reported under the contract fees section of the Official Mail Expenditure Report located in the Official Mail module of AMPS.

ff. Report misuse of appropriated fund postage to commander of the individuals involved. Determine appropriate reimbursement of postage and fees. Legal or administrative action shall be taken to obtain reimbursement.

gg. The annual review of the OPC will include verification and reporting of the designated compliance items identified on the Official Postal Manager's Inspection Checklist, and the Official Mail Expenditure Report located within the Official Mail Module of AMPS.

GLOSSARY

G.1. Acronyms.

ACSA	Acquisition and Cross Servicing Agreements
AMC	Air Mobility Command
AMPS	Automated Military Postal System
AMS	Address Management System
AOR	Area of Responsibility
APDS	All Purpose Date Stamp
AWOL	Absent without leave
BMEU	Business Mail Entry Unit
CAC	Common Access Card
CAO	Casualty Assistance Officer
CBRNE	Chemical, Biological, Radiological, Nuclear and Explosive
CCDR	Combatant Commander
CFS	Computerized Forwarding Service
CI	Congressional Inquiry
CPR	Community or Consolidated Postal Room
COA	Change of Address
COCOM	Combatant Command
CONUS	Continental United States
COOP	Continuity of Operations
COPE	Custodian of Postal Effects (USPS term is Stock Custodian)
DFAS	Defense Finance and Accounting Services
DL	Distance Learning
DMM	Domestic Mail Manual
DoD	Department of Defense
DoDD	Department of Defense Directive
DoD EA	Department of Defense Executive Agent
DoDI	Department of Defense Instruction
DoS	Department of State
DoT	Department of Transportation
EC	Eagle Cash
EDP	End Delivery Point
EOD	Explosive Ordinance Disposal
EPW/DP	Enemy Prisoners of War/Detained Personnel
ETP	Exception to Policy
FEDSTRIP	Federal Standard Requisitioning and Issue Procedure
FM	Free Mail

FMR	Federal Management Regulation
GSA	General Services Administration
GTC	Global Trade Compliance
HNA	Host Nation Agreement
HQ	Headquarters
HRH	Hand-Receipt Holder
IAD	Intrusion Alarm Devices
IAW	In Accordance With
ICAIR	International Commercial Air
ICL	Individual Country Listing
IDS	Intra / Inter Theater Delivery Service
IEO	International Exchange Office
IPTA	Inter-service Postal Training Activity
ISC	International Service Center
ITRO	Inter-service Training Review Organization
JMPA	Joint Military Postal Activity
LCM	Letter Class Mail
LCR	Legal Sufficiency Review
MCA	Mail Control Activity
MILAIR	Military Airlift
MMT	Military Mail Terminal
MOA	Memorandum of Agreement
MOU	Memorandum of Understanding
MPA	Military Postal Activity
MPO	Military Post Office
MPS	Military Postal Service
MPRB	Military Postal Service-Publications Review Board
MPSA	Military Postal Service Agency
MRC	Mail Recovery Center
MRI	Mobile Routing Instruction
MTT	Mobile Training Team
NEO	Non-combatant Evacuation Operation
NGO	Non-Government Organization
O&D	Origin and Destination
OCONUS	Outside Continental United States
OGA	Other Government Agency
OJT	On the Job Training

OM	Official Mail
OMP	Official Mail Program
OPC	Official Postal Center
OPM	Official Postal Manager
OPSEC	Operations Security
OSP	Outside Piece
OTJAG	Office of the Judge Advocate General
PARITS	Protocol for Alarm Resolution at International Transit Sites
PC	Postal Clerk
PCS	Permanent Change of Station
PDF	Portable Document Format
PEP	Personnel Exchange Program
PES	Private Express Statute
PFO	Postal Finance Officer
PMEMS	Priority Mail Express Military Service
PNA	Postal Net Alert
POI	Program of Instruction
POM	Postal Operations Manual
POS	Point of Sale
PSC	Postal Service Center
PSO	Physical Security Office
PTR	Product Tracking and Reporting
PVR	Postal Voting Representatives
RAO	Routing Address Only
RDD	Required Delivery Date
RMRI	Return Mobile Routing Instruction
RSS	Retail Systems Software
RTS	Return to Sender
SAM	Space Available Mail
SC	Stock Custodian (Also see Custodian of Postal Effects)
SCC	Service Component Command
SDDC	Surface Deployment and Distribution Command
SECDEF	Secretary of Defense
SFA	Standard Field Accounting
SME	Subject Matter Expert
SMITR	Supply Management International Transportation Request
SOFA	Status of Forces Agreement
SOP	Standard Operating Procedures
TAD	Temporary Additional Duty
TCMD	Transportation Control and Movement Document
TDY	Temporary Duty

UAA	Undeliverable As Addressed
UCMJ	Uniform Code of Military Justice
UN	United Nations
UPC	Unit Postal Clerk
UPO	Unit Postal Officer
UPR	Unit Postal Room
UPU	Universal Postal Union
U.S.	United States
U.S.C.	United States Code
USD(A&S)	Under Secretary of Defense Acquisition and Sustainment
USPIS	United States Postal Inspection Service
USPS	United States Postal Service
ZIP	Zone Improvement Plan

G.2. Definitions. Unless otherwise noted, these terms and definitions are for the purpose of this manual.

Accountable Equipment. DoD and USPS serialized items or those designated by MPSA and listed on a PS Form 1590.

Address Change Service (ACS). Forwarding, return, or address correction service included within a mail class. Depending on the mail class, these services are performed at a charge or at no additional charge, if and when the service is actually rendered.

Address Management System (AMS). Master database of deliverable addresses. Address-checking tools using AMS provide address standardization, as well as city/state and ZIP Code lookup features. Business mailers use the USPS AMS database to standardize addresses by correcting errors in street addresses and city names and to return the correct ZIP Code.

Automated Military Postal System (AMPS). A web-enabled management system that integrates and optimizes business processes across the USPS and the DoD.

Appropriated Fund Postage. Postage paid for with funds appropriated by the United States Congress. The postage may be prepaid or penalty postage.

Acquisition and Cross Servicing Agreements (ACSA). The formal mechanisms that allow the U.S. DoD to acquire, and in some cases to provide, logistic support, supplies, and services directly from/to eligible countries and international organizations.

Business Mail. Different types of mailing and shipping services geared towards business mailing of the government. Business mail includes bulk mailing also referred to as OM.

Business Mail Entry Unit. Area of a postal facility where mailers present commercial and permit mail for acceptance.

Business Reply Mail. Specially printed postcards, envelopes, cartons, and labels that may be mailed without postage prepayment. Postage and fees are collected when the mail is delivered back to the original sender. This domestic service enables authorized mailers to receive First-Class Mail, without prepaid postage, back from customers by paying the postage and a fee on receipt of the mail pieces. (Compare with courtesy reply mail, International Business Reply Service, and meter reply mail).

Casualty Mail. Mail addressed to an individual who is injured, missing, or deceased and is being handled through official casualty assistance channels.

Card. Refer to the USPS Domestic Mail Manual, Section 101 Physical Standards. Card correspondence must meet requirements for mail, other than postage.

Certificate of Mailing. A supplemental mail service that provides a receipt prepared by the mailer as proof of mailing.

Certified Mail. An extra-service that provides the sender with a receipt at the time of mailing; a record of delivery is kept at the post office of address. This type of mail must be sent at the regular First-Class Mail or Priority Mail rate. It is dispatched and handled in transit as ordinary mail. A record of mailing, not maintained by the originating post office where mailed.

Click-n-Ship. An online, web-based service offered by the USPS which allows customers to create pre-paid shipping labels on standard printing paper. Used herein as an example for all patron self-service options on purchasing postage and extra-services for mail pieces. For MPS operations this is an option for patrons to send mail.

Closed Pouch Operation. All mail for a respective location/operation must fit inside a mail pouch. No outside pieces are authorized.

Component OPM. The official postal manager for a Defense Agency, Military Service or Combatant Command.

CONEX. A securable metal shipping container used to transport postal items by road, rail, sea, or air. These containers have a standard length of 10, 20 or 40 ft., a standard height of 8 ft 6 in. and width of 8 ft.

Consolidated Mail. Two or more pieces of mail placed in one receptacle for direct mailing to one addressee, one installation, or more than one installation served by the same postal center.

Consolidated Postal Facility (CPF). Centralized metering location serving multiple installations or commands within a geographic region where IC, OM, and/or PM are processed.

Consolidated (or Community) Postal Room (CPR). A standalone facility, separate from the servicing MPA. A function of the MPS designated to deliver postal to customers, through individual mail receptacles, and support multiple units or organizations. The CPR conducts business through a customer service window that provides all or a combination of the following services: issuance, maintenance, and withdrawal of individual mail receptacles, receipt and processing of postal items, delivery of accountable mail, general delivery service, directory service, and customer complaints and inquiries. CPRs may accept out-going letter-class postal (only) with postage, indicia, or endorsement (in lieu postage) applied, and transfer to the servicing MPO for dispatch. CPRs do not offer retail services. CPR is one of the exclusively authorized military address types used in the Delivery Address Line for APO/FPO military mail OCONUS (i.e., CPR 301 BOX 2134).

Container. A securable, large metal box, or vehicle used to transport postal items by road, rail, sea, or air.

Continuity of Operations Plan (COOP). A plan to ensure that primary mission-essential functions continue to be performed during a wide range of emergencies, including localized acts of nature, accidents and technological or attack-related emergencies. The critical business functions your COOP is planning for are those which must be: (1) Operational not later than 12

hours after activation. (2) Capable of maintaining sustained operations for up to 30 days.

Contingency Operation. As defined in Section 101(a) (13) of Title 10, U.S.C., military operations that are designated by the Secretary of Defense as an operation in which Service members are or may become involved in military actions, operations, or hostilities against an enemy of the U.S. or against an opposing military force. It also includes military operations that result in the call or order to, or retention on, active-duty uniformed service members under various laws during a war or national emergency declared by the President or Congress.

Contractors Authorized to Accompany the Force (CAAF). All tiers of contractor personnel (and subcontractor) authorized to accompany the force during specific contingency operations afforded status and support privilege through a letter of authorization. Generally, this includes all U.S. citizen and Third Country National employees not normally residing within the operational area; whose area of performance is in the direct vicinity of U.S. forces and who routinely are co-located with U.S. forces (especially in non-permissive environments). In some cases, CCDR subordinate commanders may designate mission-essential host nation or local national contractor employees (e.g., interpreters) status and support privilege. This status and support privilege does not apply to contractor personnel in support of contingencies within the boundaries and territories of the United States.

Correspondence. Letters, cards, flats, or parcels either personal or official, that does not have postage or extra-services applied, must comply with PES requirements within the United States, and has the same protections as postage paid mail.

Critical Information Requirement (CIR). A serious incident (such as loss of mail, closing of a critical node in the network, death, or serious injury to a postal employee, etc.) within the postal community that must be reported through the chain of command to MPSA via AMPS.

Custodian of Postal Effects (COPE). (USPS term is Stock Custodian) Military service members, DoD civilian employees or contractors accountable for administration of the postal effects entrusted to them by the USPS.

Deferred. Lowest transportation priority for movement of mail. Old term was space available.

Direct Support. Sorting of mail for issue to addressees or postal clerks and mail orderlies, and the sorting of mail received from addressees, postal clerks, and mail orderlies for onward dispatch to another postal facility. This includes accepting, collecting, canceling, sorting, redirecting, massing, sacking, weighing, manifesting, and dispatching mail. It may also include postal finance services provided to patrons when required.

Dispatch. Postal items moved to the next location until final disposition.

Electronic Funds Transfer (EFT). Electronic transfer of money from one bank account to another, either within a single financial institution or across multiple institutions, via computer-based systems, without the direct intervention of bank staff.

End Delivery Point (EDP). A single mailbox or other place at which mail is delivered.

Endorsement. A marking on a mail piece that shows handling instructions, an extra-service, or a request for an ACS.

Expedited. The highest transportation category for mail. Normally pertains to Priority Mail Express Military Service. May also apply to use of express small parcel carriers for overnight service.

Extra Services. Provide enhancements that offer greater security and accountability for mail, convenience for the sender, and special handling options. Some extra services include insurance, Certified Mail, COD, Registered Mail, Adult Signature, USPS Tracking, Signature Confirmation and more. Fees for extra services are in addition to postage.

Facility and Equipment Upgrade Plan. The plan identifies and allocates resources for facility improvements and equipment upgrades or replacement as part of the planning, programming, budgeting, and execution system usually within the coming five years.

First Class Mail. Mail weighing up to 13 ounces.

Flat. Refer to the USPS Domestic Mail Manual, Section 101 Physical Standards. Flat correspondence must meet requirements for mail, other than postage.

Flat-Size Mail. A mail piece that exceeds one of the dimensions for letter-size mail (11-1/2 inches long, 6-1/8 inches high, 1/4 inch thick) but does not exceed the maximum dimension for this mail processing category (15 inches long, 12 inches high, 3/4 inch thick). The dimensions are slightly different for automation rate eligibility. It may be unwrapped, paper-wrapped, sleeve-wrapped, or enveloped.

Franked Mail. OM sent without postage prepayment by members and members-elect of Congress, the vice president, and other authorized individuals. Mail must relate to the mailer's official business, activities, and duties. The mail piece bears a written signature, printed facsimile signature, or other required marking instead of a postage stamp.

Free Mail (FM). A Secretary of Defense-approved privilege for First-Class mail sent from a contingency operation that must enter USPS control in accordance with Section 3401 of Title 39, U.S.C. It is postage free to the authorized patron, but DoD pays for postage and transportation costs.

Frustrated Postal. A term used to describe when a postal item is halted from onward movement, by a third-party screening service or foreign customs authority. This delay is normally due to an incident that may occur during the handling of prohibited items, inadmissible items, dangerous goods, or wrongly admitted items resulting in the movement halt.

General Support. Bulk separation of postal for onward dispatch to another postal facility, to include the sorting of letter mail received from one civilian Post Office or RAO for dispatch to

another postal facility. It may include postal finance service, directory service, or collection and delivery service.

Global Trade Compliance (GTC). The process by which goods enter/import into a country in conformance with all import laws and regulations of that country. It is also the process by which goods exit/export out of a country in conformance with all export laws and regulations.

Hand Receipt Holder (HRH). An employee who, either by position or by designation, assigned direct responsibility for the accountability and security of USPS or MPSA accountable equipment from the responsible PFO, COPE/SC of the parent MPA. Typically, for MPA operations geographic location separate from the PFO's, COPE/SC's primary daily-duty location.

Immediate Family Members. Immediate family members are: wife, husband, mother, father, stepmother, stepfather, parent through adoption, foster parents who stand or stood in loco parentis, children, stepchildren, and children through adoption, brothers, sisters, half-brothers and half-sisters.

Indicia. (Permit Imprint) An imprint on each mail piece signifying that postage has been prepaid. An indicia takes the place of a stamp or postage meter imprint and is generally printed directly on the pieces to be mailed.

Individual Delivery Point. Delivery service provided to a physical or virtual receptacle designated by the management of the development for the receipt of mail which will be distributed by its employees.

Inherently Governmental Functions (IGF). The term "inherently governmental function" is defined by the Office of Federal Procurement Policy Letter 11-01 and is used when referring to a particular task or function that must be performed by a government official. IGF is a policy term which encompasses those governance areas that require officials to exercise discretion, e.g., policy decision-making, performance/mission accountability, and execution of monetary transactions and entitlements. If a task or function is not determined to be inherently governmental, it may be eligible for performance by private sector contractors through a contract or other service arrangement. In general, government policy limits contractors to the performance of common commercial services (custodial, aircraft maintenance, refuse removal, grounds keeping, etc.) and other services related to gathering information on its behalf for the purpose of advising, offering opinions, providing recommendations and/or presenting ideas. These types of services are not inherently governmental because they do not require contractors to establish Government policies, render actionable mission/organizational decisions, or expend taxpayer dollars.

International Exchange Office (IEO). An IEO is a MPA that interfaces with the host nation postal system to facilitate misdirected international or official LCM exchange.

International Mail. Mail that originates in one country and arrives in another country. Mail to and from MPOs is considered domestic mail, not international mail, unless the mailing or

delivery address contains the name of a foreign city and country.

Inter-service Postal Training Activity (IPTA). Military Postal Service training facility hosted by the Army and staffed by military and civilian instructors from the United States Army, Marine Corps and Air Force. Provides basic and supervisory postal skills involved in the operation of a MPA for service in the operating forces and supporting establishments.

Intra Organization Hand Receipt. Custody process performed in AMPS, PS Form 1590/ Hand-Receipt Holder module, for USPS and MPSA accountable equipment maintained by an activity organizationally aligned (same or no ZIP Code) with that of the responsible PFO or COPE/SC. The responsible PFO or COPE/SC initiates hand receipt accountability actions to the individual in possession of item.

Intra/Inter Theater Delivery Service (IDS). A service established to send correspondence between MPOs outside the U.S. and USPS control, endorsed “IDS” in the upper right corner.

Joint Military Postal Activity (JMPA). Subordinate organization of MPSA co-located at USPS facilities for liaison and monitoring of the in-transit processing, dispatch, and transportation of military mail addressed to and from overseas MPAs.

Letter. For a definition, refer to the USPS Domestic Mail Manual, Section 101 Physical Standards. Letter correspondence must meet requirements for mail, other than postage.

Letter of Authorization (LOA). A letter completed by the Contracting Officer stating the intended length of assignment in the theater of operations. Identifies use of Government facilities and privileges in the theater of operations, as authorized by the contract. Authorizations may include such privileges as access to the exchange facilities, the commissary, and use of Government messing and billeting. The LOA must include the name of the approving Government official.

Library Rate. A Package Services subclass for items on loan from or exchanged between academic institutions, public libraries, museums, and other authorized organizations. NOTE: This is a congressionally subsidized rate and is not authorized for use by DoD activities.

Mail. Letters, cards, flats, and parcels which have postage affixed; paid for by a USPS customer, authorized DoD patron, or by DoD for FM.

Mail Control Activity (MCA). An MPA located on a military or civilian airport; may be co-located with a MMT. MCAs act as the U.S. military mail traffic manager for the terminal, and maintain inventory control to ensure mail tendered is moved per agreement schedules. Coordinate with the JMPAs (MPSA), other MCAs, carriers, ground transportation managers, AMC, and other organizations to develop routing schemes, and coordinate expected mail volumes. Monitor carrier and terminal storage area to ensure adequate security and protection of mail in their custody and ensure efficient and proper mail movement requirements are maintained. Observe mail transit times IAW established information systems, and alert network agencies of potential issues or delays in the transportation network.

Mail Cover. A non-consensual record of information on the outside of mail or correspondence items for sealed mail or contents of unsealed items to an addressee. The purpose is to locate a fugitive, protect national security, assist in the identification of property and assets forfeitable under law, or obtain evidence of either a violation of postal statute or a crime punishable by a prison term.

Mail Recovery Center (MRC). A postal facility designed only to receive and attempt to return undeliverable and mail of obvious value, which cannot be forwarded. (Formerly known as “Dead Letter/Parcel branch)

Military Mail Terminal (MMT). An MPA also known as Joint Military Mail Terminal (JMMT), Fleet Mail Center (FMC) and Air Mail Terminal (AMT). MMT may be located at or near an airport, that concentrates, transfers, receives, distributes, and dispatches postal transported principally via air or surface. MMTs sort incoming and outgoing postal and distribute by address (ZIP Code and/or Unit). MMT’s load and offload ground transportation vehicles/containers, aircraft Unit Loading Devices (ULD), and resolve issues on commercial and military modes of transportation.

Military Postal Activity (MPA). Any military postal facility staffed by postal personnel providing postal support for the MPS at a specified location.

Military Post Office (MPO). An MPA designated as either an Army/Air Force Post Offices (APO), or Fleet (Navy/Marine Corps) Post Office (FPO). MPOs provide services comparable to a USPS Post Office, including personal and official mail, retail services, and receipt and delivery of postal items to authorized patrons.

Military Post Office (MPO) Capability. Refers to the size of the facility, number of receptacles (if applicable), and number of postal personnel.

Military Postal Service (MPS). The DoD postal organizations, personnel, and facilities used to process, transport, and distribute postal items for DoD authorized patrons. The MPS provides service to postal room locations, operates MPOs, MCAs and MMTs primarily overseas and OPCs primarily in the U.S.

Military Postal Service Agency (MPSA). A jointly staffed agency providing strategic direction, technical and procedural guidance, coordination, and assistance for the MPS to promote compliance with U.S. law and USPS, GSA, and DoD issuances. MPSA is the single DoD point of contact with the USPS.

Military Postal Service-Publications Review Board (MPRB). The MPRB is the governing-body assembled to evaluate changes to the MPM through suggestions made by MPS stakeholders and AMPS users. The MPRB evaluates suggestions pertaining to handling, processing, and transportation of personal and DoD Business/Official postal for authorized users of the MPS; both CONUS and OCONUS.

Office of the Judge Advocate General (OTJAG). The OTJAG provides legal services, and Legal Sufficiency Review (LSR) for [MPSA] postal publications IAW DoDD 5101.11E, 2.5.a.

Official Correspondence. Incoming or outgoing correspondence relating to business of the Federal Government.

Official Mail (OM). Incoming or outgoing mail that is related to official business of the Federal Government.

Official Mail Program (OMP). A program to manage DoD business mail and correspondence.

Official Postal Center (OPC). An MPA where DoD business mail and correspondence, small parcel express carrier items, and occasionally personal mail are received, sorted, and distributed. OPCs process and apply postage to official correspondence and process personal and OM. OPC is one of the exclusively authorized military address types used in the Delivery Address Line for APO/FPO military mail OCONUS (i.e., OPC 301 BOX 2134).

Official Postal Manager (OPM). A formally trained and appointed OPM who serves as the official mail program manager for either DoD, a DoD Component, an installation, or multiple installations with oversight and responsibility for postal support to a postage application site(s). This individual advises on all official mail matters.

Patron. Individuals authorized to use MPS within and outside the United States, consistent with international agreements; laws; and Federal, USPS, GSA, and DoD regulations.

Parcel. Refer to the USPS Domestic Mail Manual, Section 101 Physical Standards. Parcel correspondence must meet requirements for mail, other than postage.

Penalty Mail. Official federal government mail, other than franked mail, which is authorized by law to be transmitted in the mail without prepayment of postage.

Penalty Postage. Penalty postage is paid for after mailing versus prepaid postage that is paid for when obtained. Forms of penalty postage are penalty-metered indicia, penalty permit indicia, penalty mail stamps, penalty business reply and merchandise return indicia.

Periodicals. Magazines, journals, newspapers, digests, briefs, bulletins, summaries, and similar items published on a recurring basis.

Permit Imprint. (Indicia) An imprint on each mail piece signifying that postage has been prepaid. An indicia takes the place of a stamp or postage meter imprint and is generally printed directly on the pieces to be mailed.

Permit Mail. Method of paying for business mail with appropriated funds using a postage meter imprint and meeting specific USPS rules.

Personal Mail. Incoming or outgoing mail that is not related to official business of the Federal

Government. To include Free Mail with DoD postage paid and affixed.

Personnel Exchange Program (PEP). A program authorized by 10 U.S.C., Section 168 where military and civilian personnel of the Department of Defense and the defense ministries/ departments and/or armed services of foreign governments occupy positions with and perform functions for a host organization to promote current or future international programs, greater mutual understanding, and interoperability with allies and coalition partners.

Postage Evidencing System. A device or system of components a customer uses to print evidence that postage required for mailing has been paid.

Postal. Personal and official mail, and personal and official correspondence.

Postal Clerk (PC). Postal personnel who perform retail services for personal and official mail, and postal duties at MPAs.

Postal Facility. See Military Postal Activity.

Postal Finance Officer (PFO). Postal personnel formally trained and designated in writing, responsible for managing postal finance and retail services at one or more MPOs.

(Unit) Postal Orderly. Postal personnel who perform postal duties within a unit or organization.

Postal Net Alert (PNA). An alert used to notify MPAs of transportation or infrastructure issues affecting USPS or MPS networks that may delay postal items. A PNA is normally for informational purposes but may lead to an investigation, which may require Postal Report.

Postal Report. Report on acts that violate laws, agreements, USPS, and DoD regulations, or jeopardize the security of mail and other USPS property.

Postal Personnel. Personnel (military or civilian) designated and trained to provide MPS support to authorized patrons.

Postal Service Center (PSC). A function of the MPS designated to deliver postal to customers, through individual mail receptacles. PSC are located within an MPO and conducts business through a customer service window that provides all or a combination of the following services: issuance, maintenance, and withdrawal of individual mail receptacles, receipt and processing of postal items, delivery of accountable mail, general delivery service, directory service, and customer complaints and inquiries. Also used as an MPS facility designation, and one of the exclusively authorized military address types used in the Delivery Address Line for APO/FPO military mail OCONUS (i.e., PSC 2 BOX 53).

Postal Support. Includes all functions performed by DoD personnel and organizations or on behalf of DoD from acceptance through delivery of postal items for DoD patrons. Postal support occurs at the strategic, operational, and tactical levels and includes administrative, management, training, and quality assurance functions.

Postmaster. A postal person in charge of an MPO.

Preferred. A transportation category for First Class and Priority mail.

Prepaid–Postage. All forms of postage except penalty postage.

Priority Mail. First-Class mail weighing more than 13 ounces.

Priority Mail Express Military Service (PMEMS). A USPS trademarked mail class that provides expedited delivery service for authorized items meeting size and weight restrictions.

Private Express Statute (PES). Civil and criminal federal laws that restrict carriage of letters over post roads (streets) to USPS employees. Exceptions allow government agency employees to carry DoD business mail, use an express carrier for expedited items or pay for the carriage by an outside entity by paying six times the normal USPS postage rate.

Production or Bulk Mailer. An organization, such as a supply warehouse or a correspondence course activity, which produces large volumes of parcels or other items for mass mailing.

Prograde. Inbound postal received.

Receptacle. A tray, tub, sack, tri-wall, con-con, or unit load device used to nest postal items for transport.

Registered Mail. USPS' most secure service that provides a chain of receipts to monitor mail movement from the point of acceptance to delivery.

Required Delivery Date (RDD). The date mail must reach the addressee.

Restricted Delivery. A supplemental mail service that generally limits who may receive an item. This service is available for a fee when used with Certified Mail, collect on delivery, insured mail, and Registered Mail.

Retail Services (RS). Also known as Postal Finance Service. MPOs use Retail Systems Software (RSS), in conjunction with the Point of Sale (POS) retail systems to provide retail support. RS may include postage and stamp sales, as well as money order sale and cashing services. RS operations provide postal acceptance and processing services; as well as extra service upon request (i.e., Priority Mail Express, Insured, Certified, Registered, Return Receipt, etc.).

Retrograde. Outbound postal dispatched.

Return Receipt. An extra-service available on registered, certified, or numbered insured mail. USPS Domestic Return Receipt (PS Form 3811) or Return Receipt for International Mail (PS Form 2865) shows to whom and when mail is delivered and is used when the mailer must have proof of delivery or date of delivery.

Routing Address Only (RAO). An MPA designation (address/Zip Code) which serves as a routing indicator for mail separation, transportation, and billing purposes only. RAOs do not provide receipt and delivery of postal, or retail services.

Secondary Unit Designator. Examples are (but not limited to): PSC, CPR, apartment, suite, floor, room, unit, stop, and department that are followed by a number placed on the same line as the street address. The secondary designator may be placed on the line above the street address if the line is too long when both are on the same line.

Seizure. The removal of the item from the mail stream. Seizures are usually the result of law enforcement or customs intervention and usually temporary in nature. The seizure should not result in undue delay in delivery of the mail item.

Self - Mailer. A mail piece excluding parcels that does not have an outer cover, wrapping, or envelope where the majority of the printing, drawing, or writing being transmitted is placed (e.g., postcards).

Single Service Postal Manager. CCDR designated organization responsible for military postal operations in a joint area of responsibility.

Stock Custodian (SC). See Custodian of Postal Effects.

Transit Time. The number of calendar days that elapse between any two given points in the movement of mail.

Transit Time Standard. The average performance standard from acceptance through delivery of mail for MPS locations based on historical data.

Unit Postal Clerk (UPC). Postal personnel who interface with the MPA and perform postal duties for a unit or organization.

Unit Postal Officer (UPO). Postal personnel, GS-6/E-6 or above who manage the postal program and UPR operations for a unit or organization.

Unit Postal Room (UPR). A designated, secure location within a unit or organization where postal items are received, sorted, and distributed. UPRs do not offer retail services. UPR is one of the exclusively authorized military address types used in the Delivery Address Line for APO/FPO military mail OCONUS (i.e., UPR 4 BOX 2).

Virtual Mail Box. The assignment of a box number to represent a delivery point in a standardized Military Mailing Address instead of an actual delivery receptacle physically present at the MPA.

G.3. Forms and Supply Items:

Form or Supply	Form or Supply Name
DDD1	ATTENTION Mail Collection Policy
DD Form 285	Appointment of Military Postal Clerk, Unit Mail Clerk or Mail Orderly
DD Form 885	Money Order Control Record
DD Form 1372-E	Mail Manifest
DD Form 1384	Transportation Control and Movement Document
DD Form 2257	Designation/Termination MPC-FPC-COPE-PFO
DD Form 2258	Temporary Mail Disposition Instructions
DD Form 2260	Unit Mail Clerk/Orderly Designation Log
DD Form 2261	Registered Mail - Balance and Inventory
DD Form 2262	Receptacle Record
DD Form 2273	Irregularities in Makeup and Dispatch of Mail
DEC 55-B	Card, Collection Time
EP-9	Registry Jacket Envelope
Form 302	Import/Export Customs Declaration
Label 150	29-Character Receptacle ID (Mail Routing Label)
OPNAV 5110/9	Mail Manifest
PS Form 17	Stamp Requisition/Stamp Return
PS Form 673	Report of Rifled Parcel
PS Form 969	Material Recycling and Disposal
PS Form 1412	Daily Financial Report
PS Form 1586	Supply Record
PS Form 1590	Supplies and Equipment Receipt
PS Form 1625	Record of Entry into Registry Section
PS Form 1957	Military Label and Tag Request
PS Form 2009	Information Concerning Mail Matter
PS Form 2734-B	Air Transportation Pay and Routing Adjustment - International and Military Mail
PS Form 2759-M	Report of Irregular Handling of Military Mail
PS Form 2865	Return Receipt for International Mail
PS Form 2942-A	Military Mail AV-7
PS Form 2976-R	USPS Customs Declaration and Dispatch Note
PS Form 3294	Cash and Stamp Stock Count and Summary
PS Form 3368-P	Accountability Examination Record

PS Form 3544	USPS Receipt for Money or Services
PS Form 3579	Notice of Undeliverable Periodical
PS Form 3801	Standing Delivery Order
PS Form 3806	Receipt for Registered Mail
PS Form 3811	Domestic Return Receipt
PS Form 3826	Registry Irregularity Report
PS Form 3831	Receipt for Article(s) Damaged in Mails
PS Form 3849	Delivery Notice/Reminder/Receipt
PS Form 3854	Manifold Registry Dispatch Book
PS Form 3877	Firm Mailing Book for Accountable Mail
PS Form 3883	Firm Delivery Receipt for Accountable Mail and Bulk Delivery Mail
PS Form 3907	Post Office Box Mail Pickup Notice
PS Form 4805	Maintenance Work Order Request
PS Form 7381	Requisition for Supplies, Services, or Equipment
PS Form 8105-A	Funds Transaction Report
PS Form 8105-B	Suspicious Transaction Report
PS Form 8139	Your Role in Protecting the Security of the U.S. Mail
PS Item 0-53A	Closures, Lockbox, and Number 1
PS Label 11-DoD	DoD Express Mail Label (Absentee Ballot)
PS Label 21	Officially Sealed Mail
PS Label 200	Registered Mail
SF 700	Security Container Information
SF 701	Activity Security Checklist
SF 702	Security Container Check sheet

REFERENCES

- Americans with Disabilities Act (ADA), July 1990, Amended September 25, 2008.
- AR 190-8/OPNAVINST 3461.6/AFJI 31-304/MCO 3461.1, Enemy Prisoners of War, Retained Personnel, Civilian Internees, and Other Detainees, 01 October 1997.
- Code of Federal Regulations, Title 48, Subpart 7.5.
- Defense Transportation Regulations 4500.9-R, current edition¹.
- DoD 5200.08-R, "Physical Security Program," April 2007, Incl. Ch. 2, October 19, 2020.
- DoD 7000.14-R, "Financial Management Policy," Chapter 102, Subchapter 3, Part 102-192, current edition².
- DoDD 1300.22, "Mortuary Affairs Policy," October 30, 2015, Incl. Ch. 2, September 2, 2021.
- DoDD 2010.9, "Acquisition and Cross-Servicing Agreements," April 28, 2003, Incl. Ch. 2, August 31, 2018.
- DoDD 3020.26, "DoD Continuity Policy." February 14, 2018.
- DoDD 3020.40, "Mission Assurance (MA)," November 29, 2016, Incl. Ch. 1, September 11, 2018.
- DoDD 3025.18, "Defense Support of Civil Authorities (DSCA)," December 29, 2010, incl. Ch. 2, March 19, 2018.
- DoDD 5101.11E, "DoD Executive Agent for the Military Postal Service (MPS) and Official Mail Program (OMP)," March 18, 2021.
- DoDD 5135.02, Under Secretary of Defense for Acquisition and Sustainment (USD(A&S)), July 15, 2020.
- DoDD 5205.02E, "DoD Operations Security (OPSEC) Program," June 20, 2012, incl. Ch. 2, August 20, 2020.
- DoDI 1100.22, "Policy and Procedures for Determining Workforce Mix," April 12, 2010, Incl. Ch. 1, December 1, 2017.
- DoDI 1100.13, "DoD Surveys," January 15, 2015, Incl. Ch.1, March 31, 2017.
- DoDI 1325.07, Administration of Military Correctional Facilities and Clemency and Parole Authority, March 11, 2013; Incl. Change 4, August 19, 2020.
- DoDI O-2000.16, Volume 1, "(U) DoD Antiterrorism Program Implementation: DoD Antiterrorism Standards," November 17, 2016, Incl. Ch. 3, May 7, 2021.
- DoDI 3020.41, "Operational Contract Support (OCS)," December 20, 2011, Incl. Change 2, August 31, 2018.
- DoDI 3020.42, "Defense Continuity Plan Development," February 17, 2006, certified current as of April 27, 2011.
- DoDI 3020.45, "Mission Assurance Construct," August 14, 2018, incl. Ch.1, May 2, 2022.
- DoDI 4000.19, "Support Agreements," December 16, 2020.
- DoDI 4525.09, "Military Postal Service," July 10, 2018, incl. Ch. 2, May 24, 2022.
- DoDM 5200.01, Volume 3, "DoD Information Security Program: Protection of Classified Information," February 24, 2012, Incl. Ch. 3, July 28, 2020.
- Federal Management Regulation, Chapter 102, Subchapter 3, Part 102-192, current edition³.

Geneva Convention (III) relative to the Treatment of Prisoners of War. Geneva, 12 August 1949.
Geneva Convention (IV) relative to the Protection of Civilian Persons in Time of War. Geneva, 12 August 1949
Joint Publication 1-0, “Joint Personnel Support,” December 1, 2020.
Military and Overseas Voter Empowerment (MOVE) Act.
Military Postal Service Agency, Strategic Postal Voting Action Plan, current edition⁴.
Military Standard MIL-STD-3007G, “Standard Practice for Unified Facilities Criteria and Unified Facilities Guide Specifications,” November 1, 2019.
Office of Federal Procurement Policy Letter 11-01 “Performance of Inherently Governmental and Critical Functions,” September 12, 2011.
Office of Management and Budget Circular No A-76, “Performance of Commercial Activities,” May 29, 2003.
Presidential Policy Directive/PPD-21 “Critical Infrastructure Security and Resilience,” February 12, 2013.
Protocol for Alarm Resolution at International Transit Sites (USPS/DoD Letter), August 14, 2018.
Uniform Code of Military Justice (UCMJ).
Uniformed and Overseas Citizen Absentee Voting Act (UOCAVA).
U.S.C., Title 10 Section 101 (Armed Forces).
U.S.C., Title 10, Section 101(a) (13).
U.S.C., Title 10 Section 1044 (Legal Assistance).
U.S.C., Title 18 Section (Crimes and Criminal Procedures).
U.S.C., Title 31 Section 1535 (Agency Agreement).
U.S.C., Title 39 (Postal Service).
USPS Contract, “International Commercial Air Contract 2019,” February 2019.
USPS Handbook AS 503 “Standard Design Criteria,” June 2010.
USPS Handbook AS 504 “Space Requirements,” July 1999.
USPS Handbook AS 506 “Architect/Engineer Project Requirements,” March 2000.
USPS Handbook DM-901 “Registered Mail,” January 2016.
USPS Handbook F-1, “Accounting and Reporting Policy,” January 2015.
USPS Handbook F101, “Field Accounting Procedures,” July 2023.
USPS Handbook PO 630 “Post Offices Serving DoD Installations,” April 2000.
USPS Manual, “Administrative Support Manual,” February 2023.
USPS Manual, “Domestic Mail Manual,” November 2023.
USPS Manual, “International Mail Manual,” November 2023.
USPS Manual, “Postal Operations Manual,” POM Issue 9, November 2023.
USPS “Postal Bulletin,” current edition⁵.
USPS Poster 84 “Suspicious Mail or Packages,” September 2006.
USPS Publication 28, “Postal Addressing Standards,” October 2022.
USPS Publication 38, “Postal Agreement with the Department of Defense,” February 1980.

USPS Publication 52, “Hazardous, Restricted, and Perishable Mail,” September 2023.
USPS Publication 199, “Intelligent Mail Package Barcode (IMpb) Implementation Guide for:
Confirmation Services and Electronic Payment Systems,” October 2023.
USPS Publication 542, “Understanding the Private Express Statutes,” June 2014.

¹ Located at <https://www.ustranscom.mil/dtr/>

² Located at <https://www.esd.whs.mil/Directives/issuances/dodm/>

³ Located at <https://www.esd.whs.mil/Directives/issuances/dodd/>

⁴ Located at <https://amps.usps.gov/>

⁵ Located at <https://about.usps.com/resources/postal-bulletin.htm>